

165-TL BALE HUGGER PARTS LIST

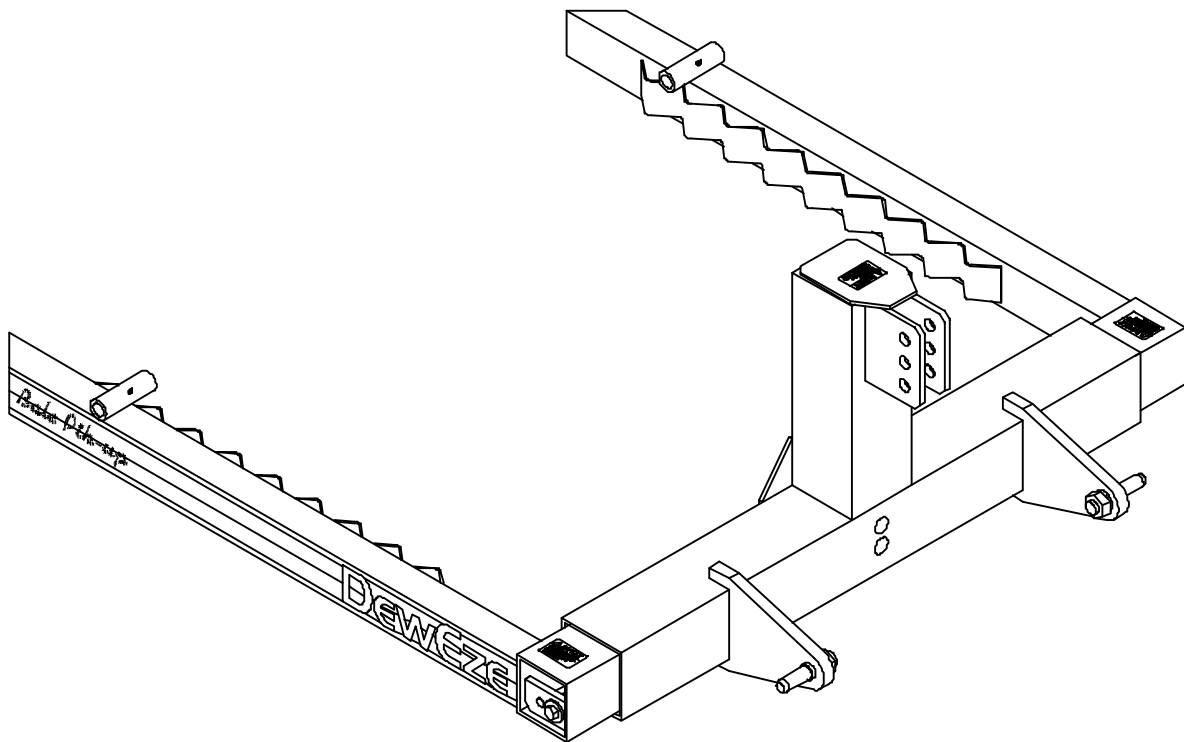

DewEze MANUFACTURING

FRONT END HUGGER ASSY

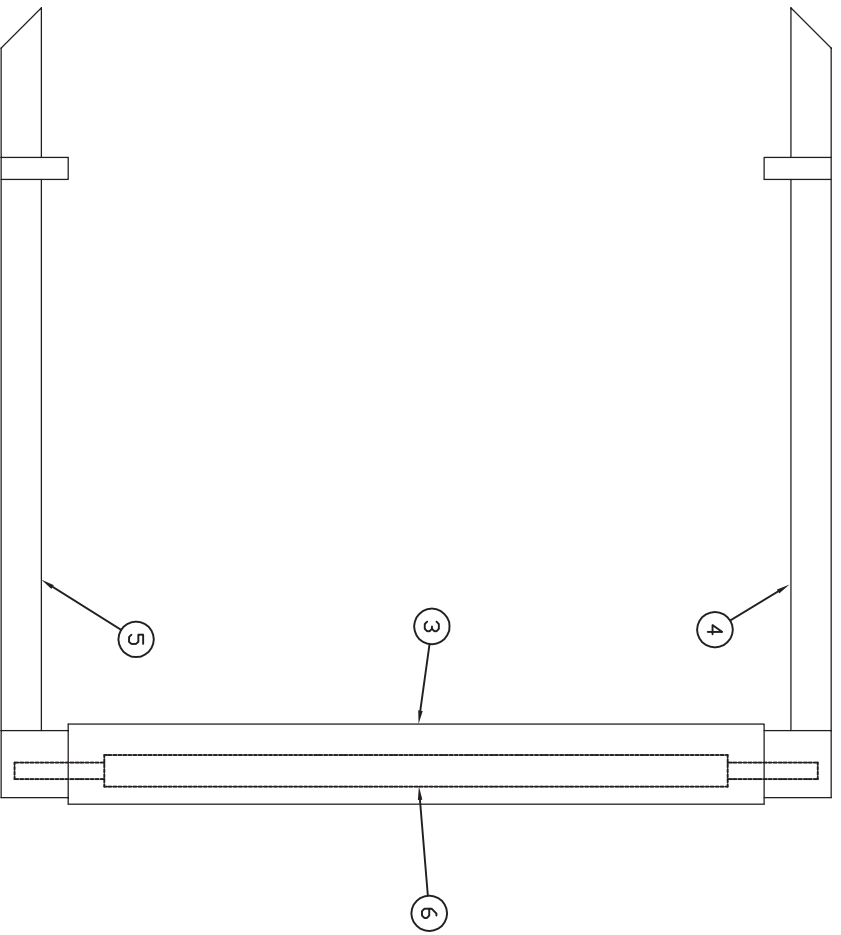

ITEM	QUAN	PART #	NAME
1	1	210441	CLAMP/LEFT
2	1	210442	CLAMP/RIGHT
3	1	210208	CROSS TUBE
4	1	210188	HUGGER ARM/LEFT
5	1	210227	HUGGER ARM/RIGHT
6	1	220002	CYLINDER

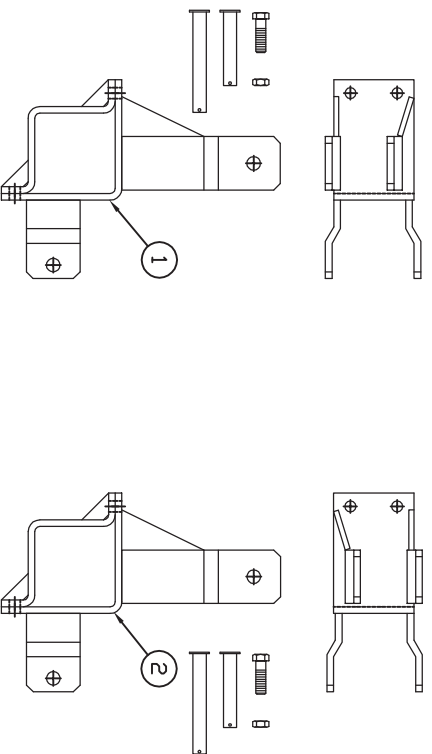

MODEL 165-TL

PART NO. 210301

210441

ITEM	QUAN	PART #	NAME
1	1	310404	CLAMP/UPPER
2	1	310405	CLAMP/LOWER
3	1	310365	PIN 5.50"
4	4	510945	BOLT 3/4NCx2 1/2
5	4	410201	NUT 3/4NC
6	1	310458	PIN 7.50"

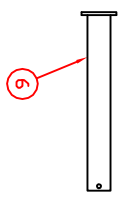
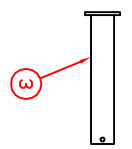
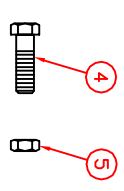
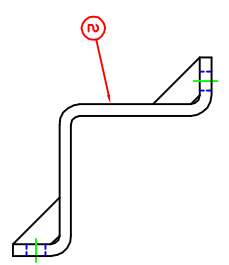
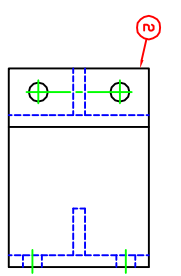
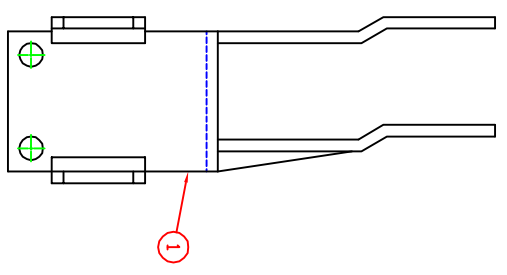
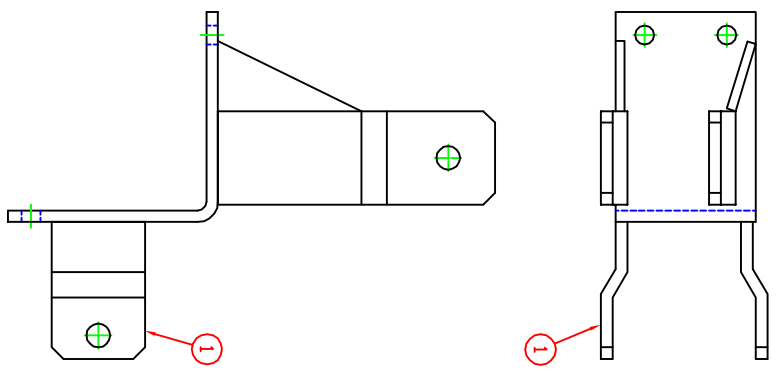

REC
A

A	LB	7-2-92	REVERSE ONE OF BRACKETS	0500
LET.	BY	DATE	REVISION	REC #

DEWEZE MFG., INC. HARPER, KANSAS

SCALE: 3/16 APPROVED BY: _____

DATE: 2-24-92 DRAWN BY: [Signature]

TOLERANCE: ±.02
 XXX ±.015 ND. RECD: 1

CLAMP ASSY/LEFT

MATERIAL: _____ DRAWING NUMBER: 210441