

# S3 SUPER SLICER

---

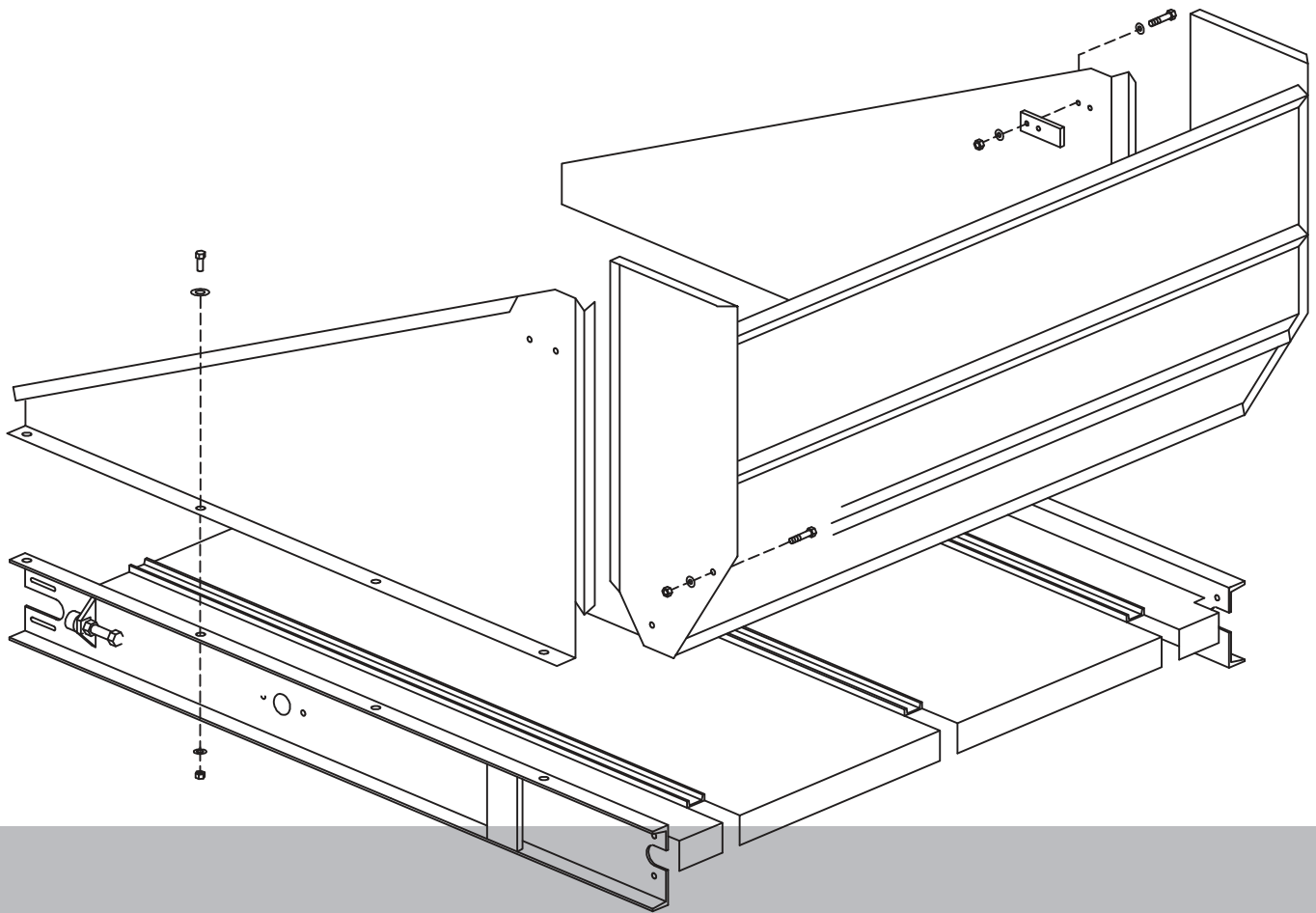

## OPERATOR'S & PARTS MANUAL



## Thank you for purchasing a Deweze S3

### TO THE OWNER OR OPERATOR:

As with all Harper products, the S3s have been thoroughly tested and built to provide a sturdy, dependable product. This manual is written as an aid to operating and maintaining the DewEze S3. Read and understand the manual thoroughly before operation to avoid damage to the unit or injury to the operator or bystanders.

A S3 can present hazards to an operator who follows unsafe procedures in either the operation or maintenance of the unit. Therefore, **SAFETY WARNINGS** are present at certain locations in the text. Harper Industries is not responsible for accidents or injuries that result from the misuse or lack of maintenance of the S3.

### SYMBOL:



**SAFETY WARNING!**



**MEANING:** Failure to understand and obey this warning may result in injury to you or others. Whenever this symbol is used, please pay very close attention to the information presented, and make sure you fully understand. If you do not, contact your dealer or Harper Industries for clarification.

## **///HARPER<sup>®</sup>INDUSTRIES, INC.**

151 E. HWY. 160 Harper, KS 67058  
(620) 896-7381 • **Fax** (620) 896-7129

**Toll Free** 800-835-1042

**Email** [info@deweze.com](mailto:info@deweze.com)

**Website** [www.deweze.com](http://www.deweze.com)

© 2026 Harper Industries, Inc.

The Harper and DewEze names are registered trademarks of Harper Industries, Inc. All other brand and product names are trademarks or registered trademarks of their respective companies.

### Statement of Warranty

Harper Industries, Inc. (HII) warrants to each purchaser of a new DewEze S3 from an authorized dealer or representative, that such equipment is free of manufacturer's defects in workmanship and materials which appear while in normal service for a period of ONE YEAR commencing with delivery to the original user.

The obligation of HII under this warranty is expressly limited, at our option, to replacement or repair at a service facility designated by Harper Industries or at the manufacturing plant in Harper, KS. A part will be replaced after inspection discloses it to have been defective. This warranty does not apply to defects caused by damage or unreasonable use (including failure to provide reasonable and necessary maintenance, or by performing functions without genuine DewEze S3 accessories) while in the possession of the consumer.

Warranty is limited to parts, labor and ground freight delivery of replacement parts. HII shall not be liable for the consequential damages of any kind, including but not limited to consequential labor costs or transportation charges in connection with replacement or repair of defective parts.

This warranty does not apply to parts subjected to misuse, abuse, alteration, improper or inadequate maintenance, or normal wear (including belts, chains, sickles).

Harper Industries makes no warranty with respect to trade accessories. They are subject to the warranties of their respective manufacturers.

ANY IMPLIED OR STATUTORY WARRANTIES, INCLUDING ANY WARRANTY OR MERCHANTABILITY OR FITNESS FOR A PARTICULAR PURPOSE, ARE EXPRESSLY LIMITED TO THE DURATION OF THIS WRITTEN WARRANTY. HII makes no other express warranty, nor is anyone authorized to make any on behalf of HII.

For further information please contact your nearest DewEze S3 dealer.

### RECORDS

Date of Purchase \_\_\_\_\_ / \_\_\_\_\_ / \_\_\_\_\_

Dealer's Name \_\_\_\_\_

Dealer's Phone \_\_\_\_\_

Serial Number Machine \_\_\_\_\_

# Table of Contents

## OPERATOR SECTION

To the Owner or Operator.....	1
Warranty Statement.....	2
Table of Contents.....	3
Specifications.....	4
Safety Guidelines.....	5
Set-Up Instructions.....	6
Operation	
Hydraulic Requirements.....	7
Loading Instructions.....	8
Feeding Instructions.....	8
Adjustments	
Feed Rate.....	8
Flow Control Valve Adjustments.....	9
Table Speed Operating Range.....	10
Suggested Rebalancing Settings.....	10
Suggested Bunk Feeding Settings.....	10
Arm Width Adjustment Measurements.....	12
Maintenance Schedule.....	12

## PARTS SECTION

Table and Feed Chain.....	1.1
Trailer Assembly.....	1.2
Hub and Bearing Assembly.....	1.3
Backboard and Sides.....	1.4
Safety Shields.....	1.5
Table Safety Stops.....	1.6
Sickle Height Adjustment.....	1.7
Twine Box - Optional.....	1.8
Decals.....	1.9
Shipping Kit Assembly.....	1.10
Sickle Drive Assembly.....	2.1
PTO Kit.....	2.2
Sickle Assy.....	2.3
PTO Holder.....	2.4
Hose Assy - PTO.....	2.5
Hose Assy - Hydraulic.....	2.6

## Specifications

<b>Power</b>	Hydraulic or PTO powered
<b>Dimensions</b>	91.63" H x 148" L x 119" W (in field position)
<b>Weight</b>	2750 lbs. w/ trailer
<b>Cutting Device</b>	81" Sickle Bar - 27 individual sickle sections (knives)
<b>Shipping Width</b>	91.63" H x 148" L 102.0" W
<b>Tire Pressure</b>	35 psi cold

***NOTE:** Following publication of this manual, certain changes in standard equipment and options may have occurred which would not be included in these pages. Your Harper dealer is the best source for up-to-date information.*

## Safety Guidelines

- Use genuine factory parts or parts with equivalent characteristics, including type, strength and material. Failure to do so may result in product malfunction and possible injury to the operator and/or others.
- If hardware is not secure, or if some of the hardware is over-tightened, equipment failure may result, posing possible safety hazards.
- To prevent possible eye injury, always wear SAFETY GLASSES while operating equipment.
- Replace locknuts and locking screws if you can tighten them without feeling considerable resistance for several turns before they are completely tight. Replace them with factory authorized parts or their equivalent.

### Guards & Shields

- Keep all safety devices in place.
- Replace all worn, damaged, unusable, missing or lost safety shields and guards before operating the equipment.
- Keep the equipment in good operating condition.
- **Table safety stops have been provided by the manufacturer and we do not recommend removing them for any reason. See parts page 1.5.**

### Safety Decals

- If safety related or instructional decals become illegible or are removed, replace them immediately. New decals may be obtained from your local Harper Dealer.
- If you replace parts that have such decals attached to them, make sure the decals are replaced with current versions, and are on the replacement parts before the machine is operated again.

### Hydraulics

To prevent serious injury or death:

- Relieve pressure on system before repairing, adjusting or disconnecting any hydraulic hose or fitting.
- Wear proper hand and eye protection when searching for leaks.
- Use wood or cardboard instead of hands when looking for leaks.
- Keep all hoses, fittings and components in good operating condition.
- Do not use any type of heat or flame (welding, soldering, cutting torch, etc.) near pressurized hydraulic lines.

 **SAFETY WARNING!**   
**HIGH-PRESSURE FLUID HAZARD!**  
**Escaping fluid under pressure can penetrate skin causing serious injury or death.**

# Set-Up Instructions

## S3 Load Arm Assembly

- Remove Load arm from inside of table, and lay on ground
- Align load arm bolt flanges with table flanges
- Bolt the load arm flanges on the back side of the table flanges, with the (9) bolts, flat & lock washers that are provided. (Refer to Image Below)



## Connect Load Cylinder to Load Arm

- Connect loading fork through loading fork frame arm flanges
- Insert washers as necessary so cotter pin sits flush (Refer to Images Below)

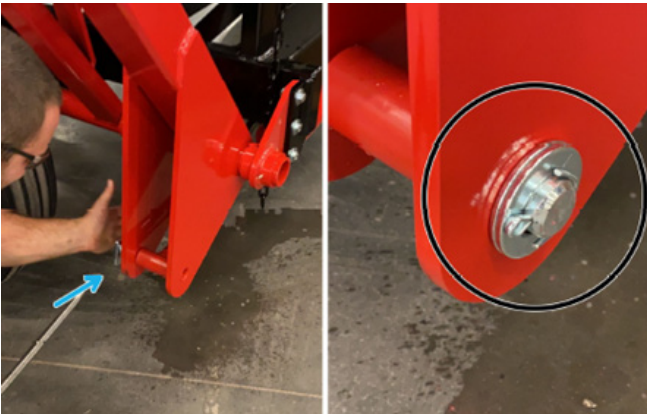

- Grease Lubrication Points on lower fork (3 Grease Zerks)



## Install Outside Fork

- Raise load arm up enough to slide the outer sleeve of the fork over the load arm, slide down to align the pin to go in place, and insert cotter pin.
- Raise load arm to upright position, and hook safety chain in place.

## Install Kicker Arm

- Install the Kicker Arm by pinning in place, ensuring that the curved side is facing down so that it can rest on the load arm slides, and insert cotter pins.

***\*Kicker Arm can only be installed if the table has been shifted over into field position.***



5. Slide table into feeding position (fig 3) and secure with bolts. The feeding position is marked on the underside of the table with bolt hole slots. The slots are located on the trailer on the angle iron rails the table is sitting on. They are shown in figures 4 & 5 on next page.



## SAFETY WARNING!

**OPERATING THE S3 LIFTING ARM WITH THE TABLE IN THE ROAD/TRANSPORT POSITION WILL DO DAMAGE TO THE LIFT ARM LINKAGE!**

Fig. 4

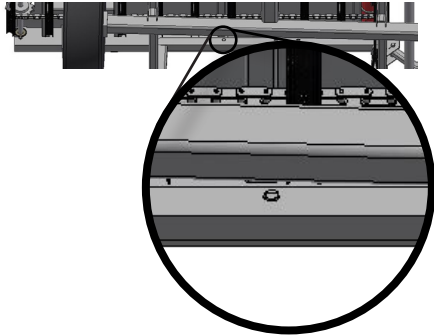
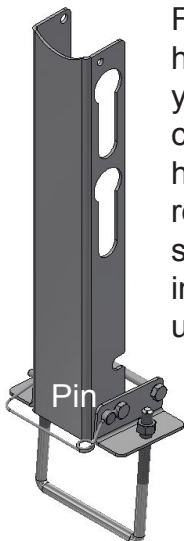
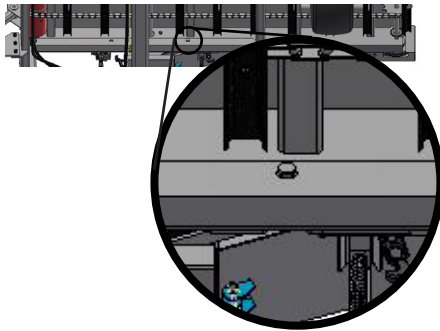

Fig. 5



For PTO machines we have installed a PTO stand for your convenience. It also contains key slots for your hydraulic hoses. The PTO shaft rests in the cutout on top of the stand and the hydraulic hoses insert into the key slots. When using S3, be sure PTO stand is in down (working) position. Do so by pulling pin and pushing down. Then reinstall pin.

## Operation

**NOTE:** BEFORE OPERATING YOUR NEW S3 MAKE A COMPLETE INSPECTION OF ALL COMPONENTS TO INSURE THAT ALL THE NUTS AND BOLTS ARE TIGHT AND THAT NO DAMAGE HAS OCCURRED DURING SHIPPING.

### HYDRAULIC REQUIREMENTS

Your new DEWEZE S3 is designed to be used as a mobile feeding unit mounted on a trailer or as a stationary unit in a permanent installation. Regardless of the type of use the S3 WILL REQUIRE 15 GPM (gallons per minute) of hydraulic oil flow and a minimum of 1800 PSI (pounds per square inch) hydraulic pressure to operate properly. Be sure that the hydraulic system you intend to use is functioning properly and that the oil is clean and of good quality.

Two hydraulic remotes are required to operate the trailer mounted S3. One is to control the lift arm for loading the bales and the other is to operate the slicer table. Each remote must be capable of reversible flow. You may want to mark the remotes to make sure that you hook up the hydraulics the same way each time you use the machine.

**NOTE:** When using a hydraulically driven S3 continuously (for more than 3 bales in 10 minutes) the following adjustments must be made to tractors equipped with a high flow, pressure compensated load sense hydraulic system.

1. Flow (speed) must be controlled on the tractor remote outlet. To set this speed first set the Slicer flow as outlined in the manual. Secondly, turn the flow control toward the “turtle” on the tractor selective control outlet until the speed begins to decrease. Stop turning as soon as you can notice a decrease in speed. Failure to follow these procedures may result in the overheating of the tractor hydraulic system, as the system will be at maximum flow and pressure. (Load is sensed at the tractor selective control valve and if this valve is wide open the system is at constant maximum pressure / flow.
2. The alternative to the above is to buy a “flow limiter valve” and attach it between the quick disconnect and the hose on the pressure side.
3. On PTO model S3, flow must also be regulated at the selective control outlet for the slat motor.

**NOTE:** If the above instructions are not followed, the following symptoms may develop:

*Rapid heating of the tractor hydraulic oil, this will show up as a loss of speed on the hydraulic motor speed. These motors lose efficiency rapidly when oil over heats.*

## LOADING INSTRUCTIONS



(Trailer Mounted Unit Only)

Approach the bale on its right side with the lift arm lowered to the ground. Cradle the bale in the lift fork by moving forward so that the bale is against the back of the fork. Lift the bale all the way up so that the bale rolls onto the table slats. Move the bale toward the sickle by activating the feeder and stop as the bale reaches the sickle. To load and carry a second bale, repeat the above process and raise the second bale until it rests snugly against the first.

**NOTE:** Be sure to raise the lift arm to the upright position and latch the safety chain whenever you transport your S3 on the road!

## FEEDING INSTRUCTIONS

To engage the feeding operation of the S3, idle the tractor engine, engage the slicer table hydraulics and increase the engine speed to the tractor manufacturer’s suggested rated speed. On a PTO slicer the PTO RPM is 540. To engage the PTO we recommend idling the engine, engaging the PTO then accelerating the tractor’s engine to rated speed for correct 540 PTO RPM operation.

 **SAFETY WARNING!**   
**Stay clear of the table and cutter bar when the machine is in operation!**

If the system stalls, reverse the slats and try again.

**NOTE:** Always wait until the first bale has been processed completely and the table slats have stopped before loading the second bale onto the table.

# Adjustments

## FEEDING RATE

The feeding rate may be adjusted by changing the speed of the feeder chain, or by adjusting the distance between the sickle and the table slats. To change this distance, use the following procedure.



### **SAFETY WARNING!**



**Turn off tractor and disconnect the hydraulic hoses before making any adjustments to the sickle! Failure to do so could result in serious personal injury!**

1. Loosen the two 5/8" hex bolts (1) and two 5/8" carriage bolts (2) that hold the sickle bar in place. (See Fig. 3)

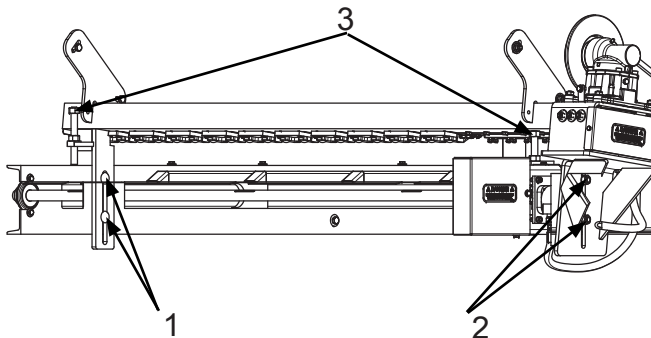

2. Screw the 3/4" all thread adjustment bolts (3) in or out at each end of the sickle. Make sure that each end is adjusted so that the sickle is parallel with the table slats. Use a tape measure to gauge each end.

**Suggestion:** When adjusting the sickle and the backboard sliding with it, loosen the bolts and nuts shown. There are nuts, bolts, and straps on both the front and rear sides of the machine.

3. Retighten the four 5/8" bolts loosened in step one on previous page.

## FLOW CONTROL VALVE ADJUSTMENT

The flow control valve on the right controls the speed of the sickle. Loosen the knob on the valve to adjust the lever and move the lever to a higher number to increase the speed. To lower the number is to decrease speed. After moving the lever, tighten the knob to hold the lever in place.

For initial setting of the valves, set each adjusting lever on "2". Fine tune the speed of the sickle and slats by adjusting the valves individually to get the proper cutting for the type of hay you are processing.

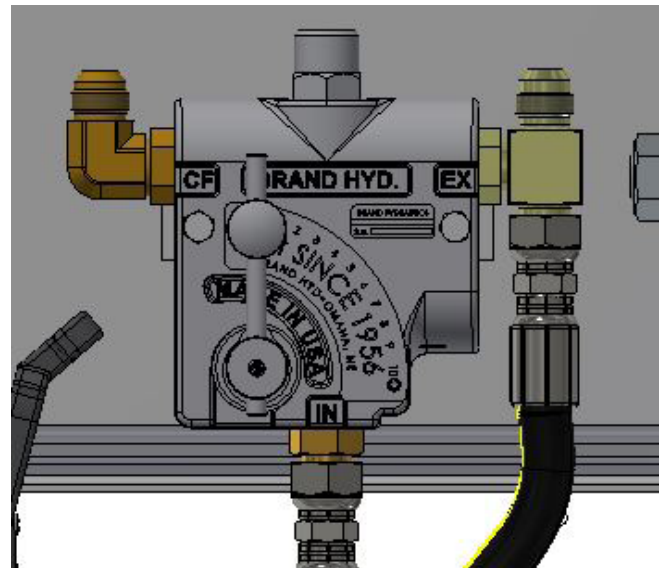

## TABLE SPEED OPERATING RANGE

- Flow Control Valve Between 2 – 7.
- Below 2 can cause the table to stall out.
- Above 7 any increase in speed with be negligible, and could allow flow to by-pass.

## SUGGESTED REBALING SETTINGS

- Leave Sickle Height at Factory Setting (3")\*.
- \*This measurement is taken at the top of the slat to the bottom of the sickle guard.*
- Set Flow Control Valve at 2.
  - Set Tractor RPM between 1500-1800 RPM.
  - Set Square Baler at Manufacturers Recommended Speed.
  - Adjust Table Flow accordingly to De-sired Output.

## SUGGESTED BUNK FEEDING SETTINGS

- Leave Sickle Height at Factory Setting (3").
- \*This measurement is taken at the top of the slat to the bottom of the sickle guard.*
- Set Flow Control at 3.
  - Set Tractor RPM between 1500-1800 RPM.
  - Make Adjustment to Table Speed, Sickle Height, and Ground Speed Accordingly, Based on Desired Feed Output.

## Arm Width Adjustment Measurements

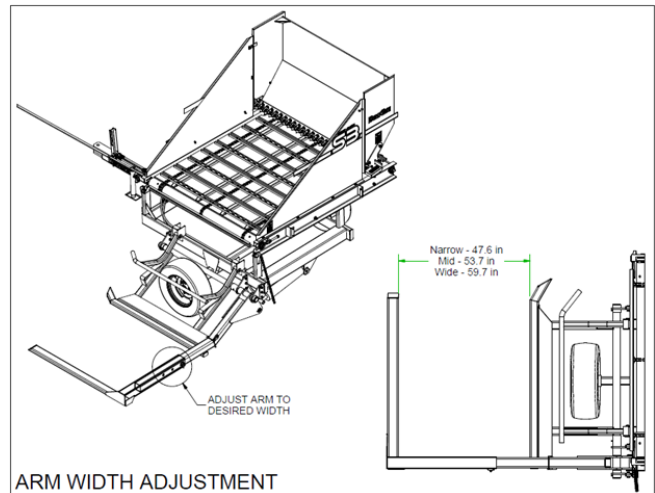



# Maintenance

## TRAILER MAINTENANCE

MONTHLY (Or every 100 bales)

- Grease the linkage of the lift arm to avoid binding and rust.

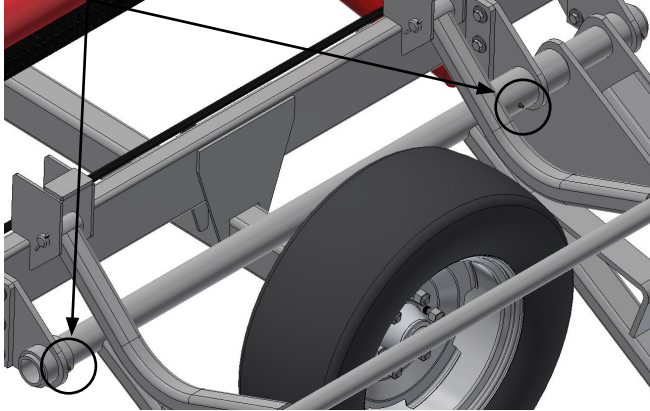

ANNUALLY

- Clean and repack the wheel bearings.

## TABLE MAINTENANCE

MONTHLY (Or every 100 bales)

- Grease Shumacher gear box with MAX 5 shots of lithium based grease every 50 operating hours.

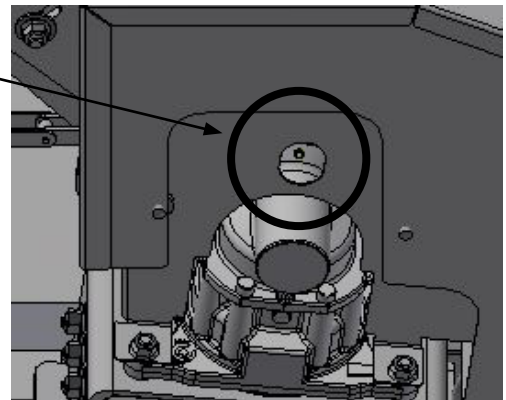
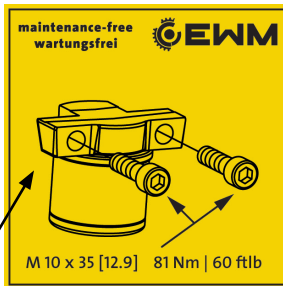

- Knife-head bearing should be greased every 12 operating hours with 1 shot of grease.
- Check the conveyor chain for tightness. The chain should not swag more than 6" from the bottom of the table at the center. Adjust the take-up roller equally at each end for maximum chain life.

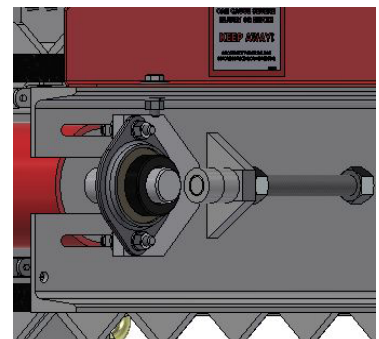
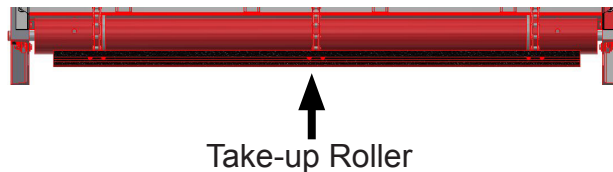
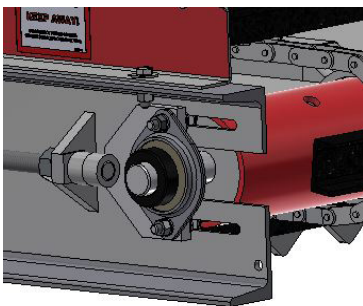

- Lubricate the system drive chains with chain oil.
  - Non-detergent petroleum based or synthetic, multigrade 20/50 oil.
- Inspect Schumacher drive belt for stretching from normal wear, tighten belt as necessary. Inspect for unusual/excessive belt wear such as fraying, glazing, or other abnormalities, replace as necessary. part # 440081 - 25-30 lbs. of tension with 3/4" deflection between tensioner pulley and Schumacher pulley.

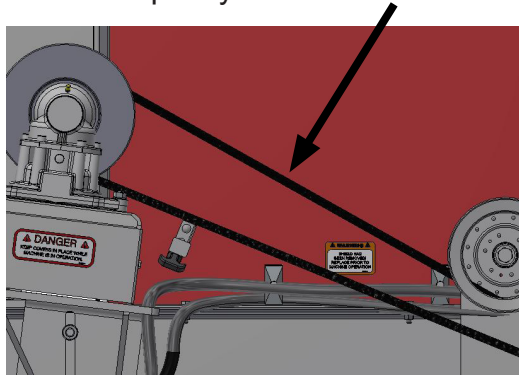

- Inspect sickle sections for wear, and replace as necessary.
- Remove lower Schumacher shield and remove excess hay from drive area.

#### BI-ANNUALLY

- Check belt tension - 25-30 lbs. with 3/4" deflection between tensioner pulley and Schumacher pulley.

### DRIVE SHAFT MAINTENANCE

#### MONTHLY (Or every 100 bales)

- Grease all grease zerks on the drive shaft.  
(Zerks located at each end and one in the middle of the shaft.)

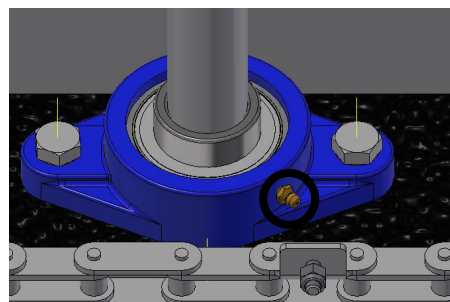
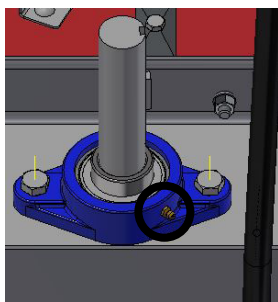

- Inspect and replace any broken or missing safety shields.
- Check for loose bolts on drive shaft.



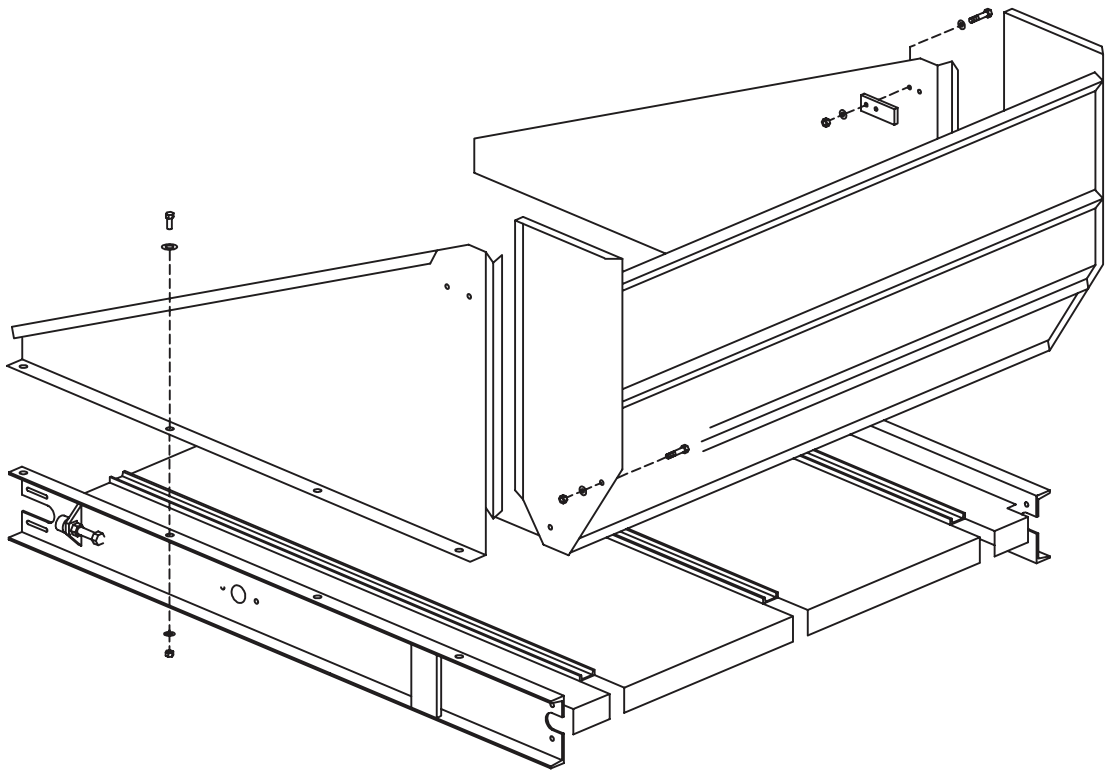

# ***PARTS SECTION***



# Table of Contents

## PARTS SECTION

Table and Feed Chain.....	1.1
Trailer Assembly.....	1.2
Hub and Bearing Assembly.....	1.3
Backboard and Sides.....	1.4
Safety Shields.....	1.5
Table Safety Stops.....	1.6
Sickle Height Adjustment.....	1.7
Twine Box - Optional.....	1.8
Decals.....	1.9
Shipping Kit Assembly.....	1.10
Sickle Drive Assembly.....	2.1
PTO Kit.....	2.2
Sickle Assy.....	2.3
PTO Holder.....	2.4
Hose Assy - PTO.....	2.5
Hose Assy - Hydraulic.....	2.6

Parts List				Parts List			
ITEM	QTY	PART #	DESCRIPTION	ITEM	QTY	PART #	DESCRIPTION
1	6	100823	Set Screw, 5/16-18 X 1.25 w/ Loctite	23	8	410233	Flange, 2 Hole
2	5	110400	BOLT, 3/8-16 X 2.0	24	4	410238	Key, 1/4 X 1/4 X 2.25
3	4	110402	Bolt, 3/8-16 X 1.25 in Carriage	25	2	410243	BEARING, 2fng Sd 1.375
4	4	110419	BOLT, 1/2-13 X 1.75	26	2	410281	ADJUSTMENT BRACKET ASSY
5	4	110420	BOLT, 3/8-16 X 1.0	27	1	410365	MOTOR ADJ. PLATE
6	4	110425	BOLT, 3/8-16 X 1.25	28	1	410370	Shield, Slat Motor
7	2	110429	BOLT, 1/2-13 X 1.5	29	1	410375	SPROCKET, 60b10 X 1.0
8	3	110437	BOLT, 3/8-16 X 0.75, WIZ FLANGE	30	1	410441	Connecting Link, Half-offset #60
9	126	110561	BOLT, 1/4-20 X .75	31	1	410442	Connecting Link, #60 Chain
10	4	110610	NUT, 1/2-13	32	3	411117	Chain, Feeder
11	4	110615	NUT, 1/2-13, UNITORQUE LOCK	33	10	411135	SLAT
12	126	110630	NUT, 1/4-20 LOCK (NYLON INSERT)	34	1	411137	SHAFT, SLAT DRIVE
13	1	110645	NUT, 3/8-16 WIZ FLANGE	35	3	411170	Half Link, Offset, 2060h
14	4	110658	WASHER, 1/2" FLAT STANDARD	36	1	411171	WELDMENT, SLAT ROLLER
15	2	110663	WASHER, 5/8" FLAT SAE	37	2	411294	CENTER BEARING MOUNT
16	16	110672	WASHER, 3/8" LOCK	38	11	415003	Toothed Slat
17	21	110676	WASHER, 3/8" FLAT STANDARD	39	1	415022	WELDMENT, TABLE
18	12	110826	NUT, 3/8-16 GR 5	40	1	420128	Motor, Eaton 101-1014 (14.1 Ci)
19	1	340007	Sprocket, 6030 X 1.25	41	1	440034	Chain, Slat Drive
20	1	400014	DECAL, SHIELD REMOVED	42	3	440070	Sprocket, 2062b13x1.25k2ss,time
21	1	405015	assembly, drive chain cover	43	1	440078	DRIVE shaft
22	5	410232	Bearing Insert, 2.83, 1.25" ec Lk				

Slats with teeth, teeth should be on far side from back board of slicer. Should be 11 slats with teeth and 10 without.

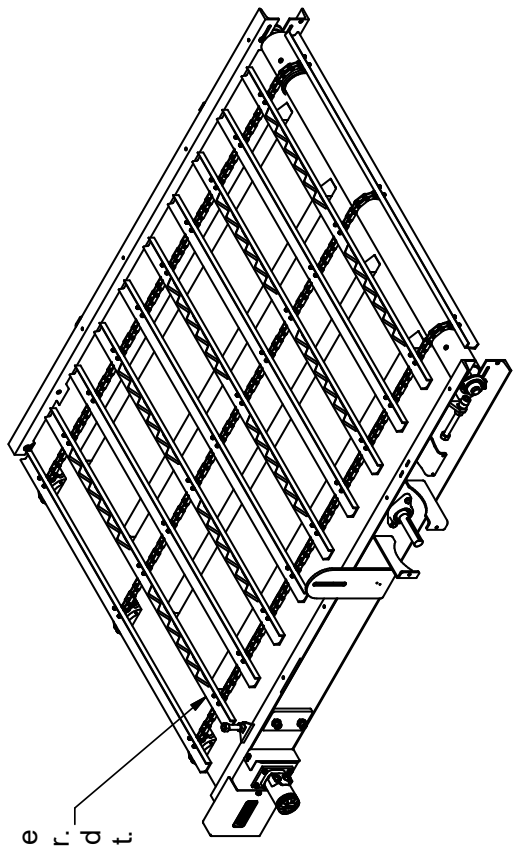

# Table and feed chain

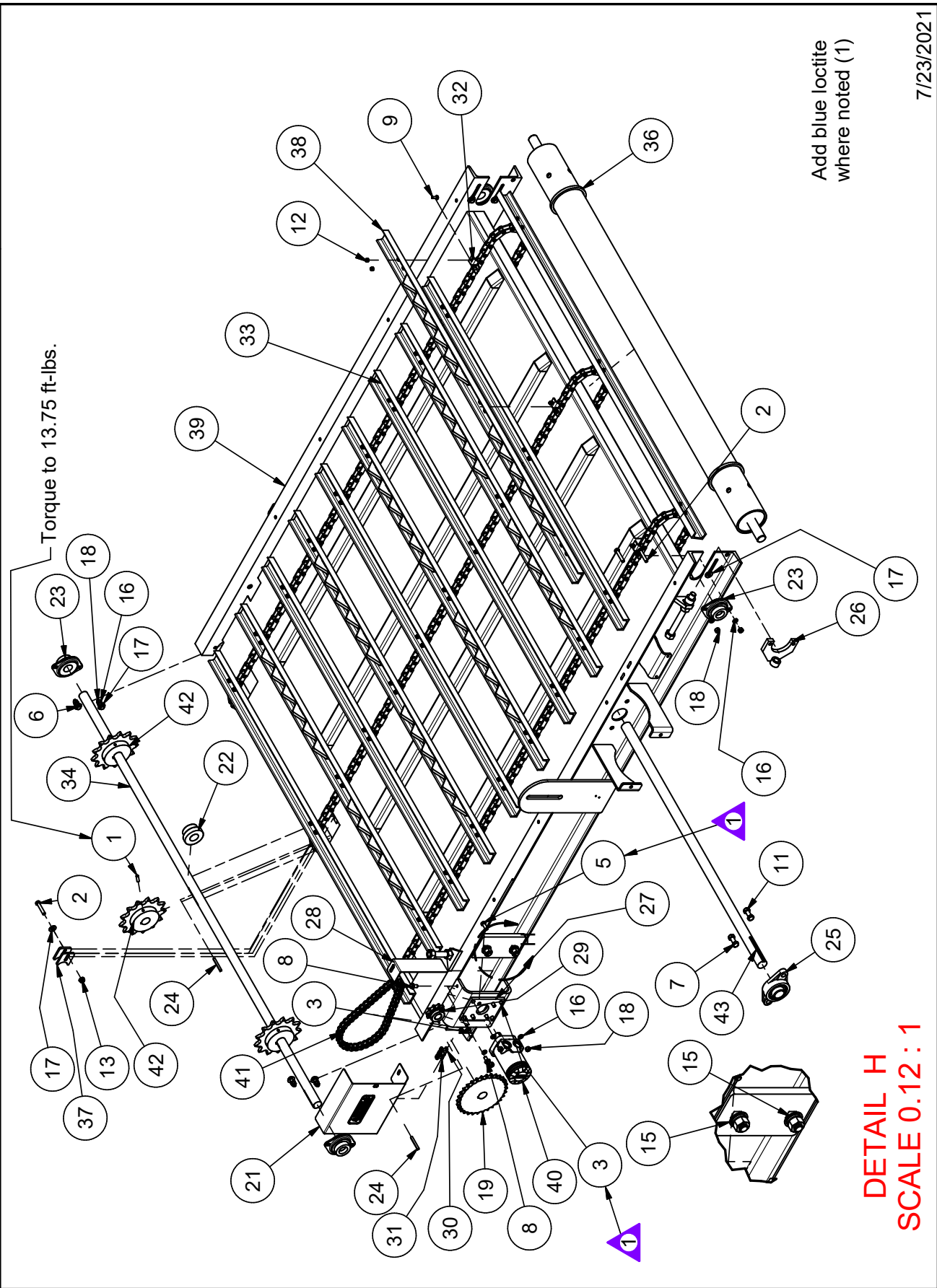

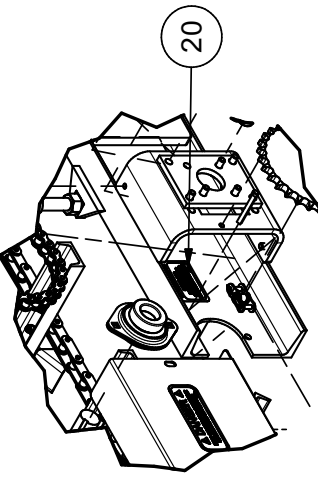
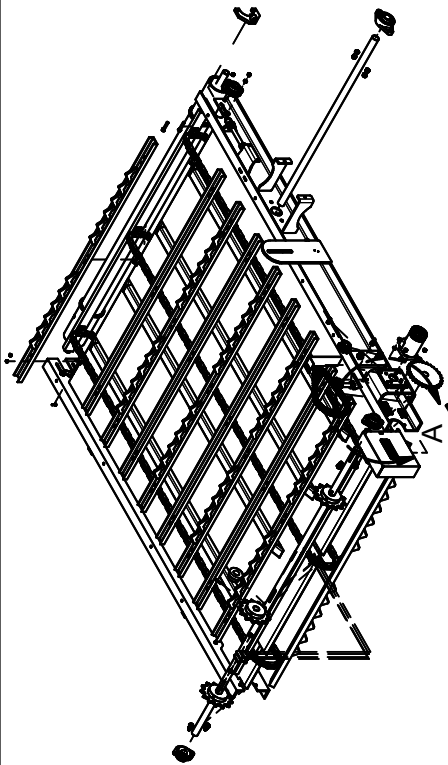

DETAIL A  
SCALE 0.1 : 1

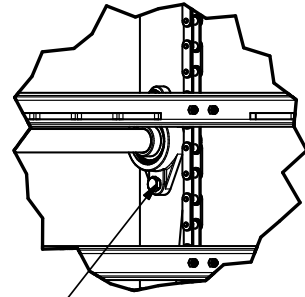
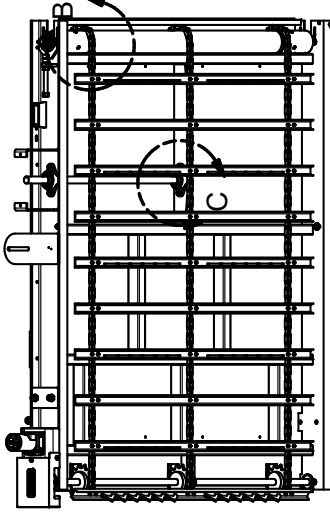

DETAIL C  
SCALE 0.1 : 1

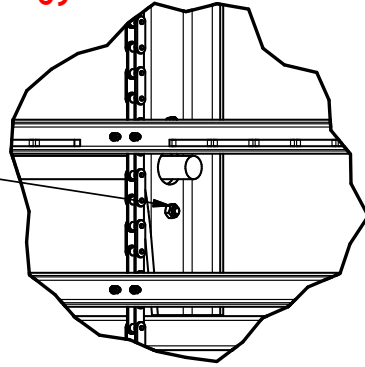

DETAIL D  
SCALE 0.1 : 1

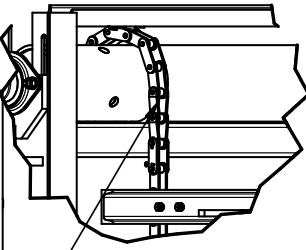

DETAIL B  
SCALE 1:1

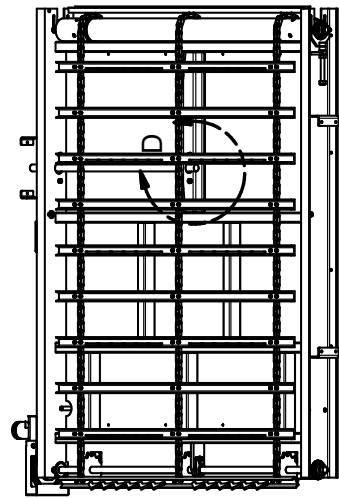

405024 REV: A

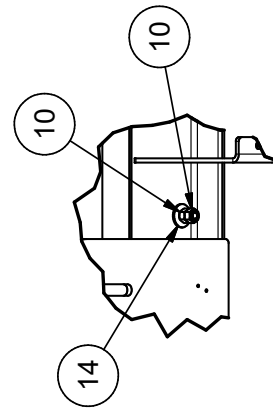
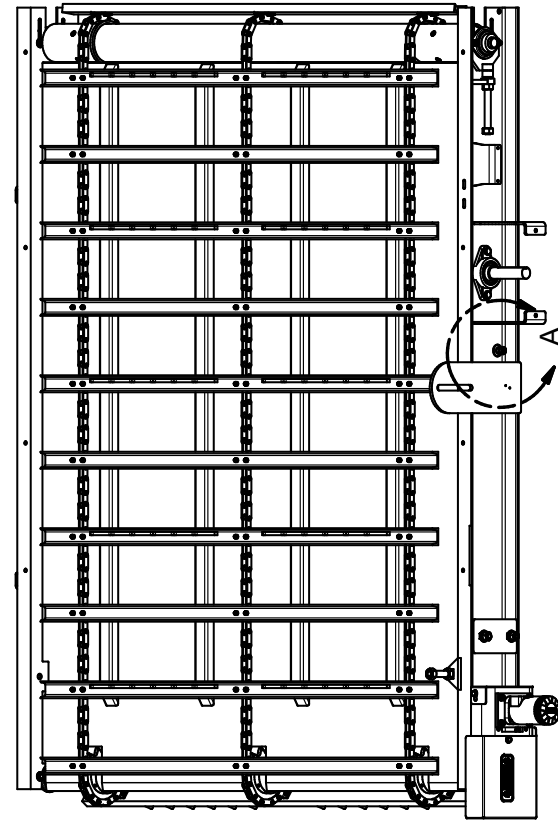

DETAIL A  
SCALE 1 / 10

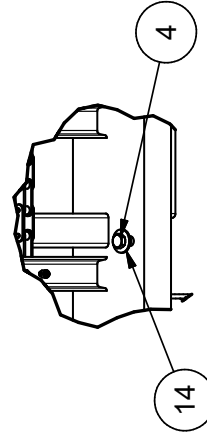
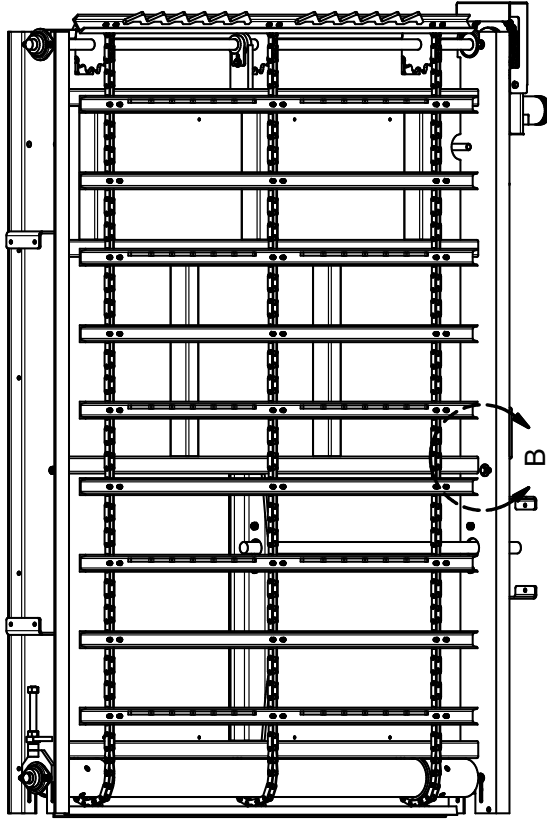

DETAIL B  
SCALE 1 / 10

Parts List			DESCRIPTION
ITEM	QTY	PART #	
1	5	102009	Cover Plate
2	5	102010	Clamp Body
3	4	110421	BOLT, 5/16-18 X 1-1/4
4	1	110491	BOLT, 5/16-18 X 2.75
5	9	110615	NUT, 1/2-13, UNITORQUE LOCK
6	18	110658	WASHER, 1/2" FLAT STANDARD
7	2	110664	WASHER, 1" FLAT SAE
8	2	110673	WASHER, 1/4" FLAT STANDARD
9	9	113008	BOLT, 1/2-13 X 2, GR8
10	2	120497	ADAPTER, 8MJ-6MB
11	2	120582	Coupler, Pioneer Male, ORB
12	1	152004	HOLDER, MANUAL
13	2	200006	DECAL, DEWEZE RED ON METALIC
14	1	410022	PIN, SWING ARM
15	1	410026	OUTER FORK ASSY
16	2	410037	WELDMENT, PIN
17	1	410069	PIN, OUTER FORK
18	1	410176	PIN, CYL BASE
19	1	410399	BALE KICKER ASSY
20	1	410715	BASIC FORK ASSY, SLICER ONLY
21	1	411159	Weldment, Trailer, S3
22	2	411290	OUTSIDE FORK MOUNT WA
23	1	420014	CYLINDER 4.0 X 18
24	1	420148	HOSE .37 X 206 6-8MB/6-8FJX
25	1	420149	Hose .37 X 224 6-8MB/6-8FJX
26	3	510174	GREASE ZERK, 1/4-28 ST
27	5	510175	COTTER PIN, 3/16 X 2
28	2	710586	SCREW, 1/4 X 1 TEK SELF-TAP
29	1	820097	CLAMP BODY

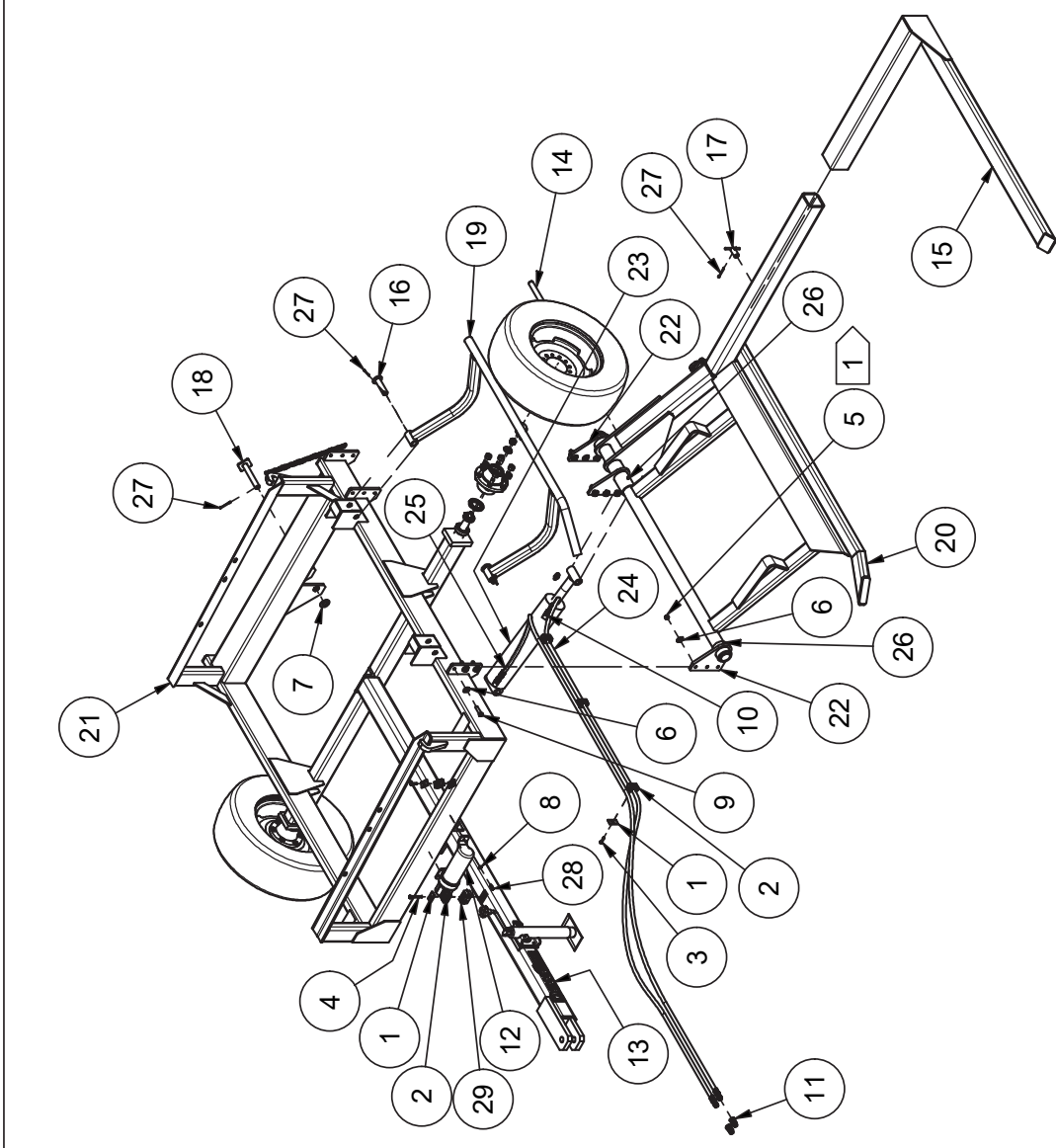

1 TORQUE TO 90 FT-LBS

# Trailer assembly and parts

11/17/2022

**NOTE:**

Pack bearing cones and lubricate seal lip with grease before assembly.

**NOTE:**

While rotating the rotor to ensure proper seating of the rollers, induce preload by using a torque wrench to tighten the adjusting nut to 50 foot pounds. Then loosen the adjusting nut one full turn. While continuing to rotate the rotor, re-torque the nut, this time to 10 foot pounds. Once again, loosen the adjusting nut, until the next castle opening and hole line up. Properly install and secure the cotter pin to prevent the nut from backing off.

Parts List

ITEM	QTY	PART #	DESCRIPTION
1	6	113006	Stud 9/16-18
2	6	113007	Nut 9/16-18
3	1	410105	SEAL
4	1	410111	Hub 6X6in
5	1	410112	DUST CAP
6	1	410114	Bearing Cup, 2.8910 X .58 & Race Combo
7	1	410115	Bearing Cup, 2.328 X .465 & Race

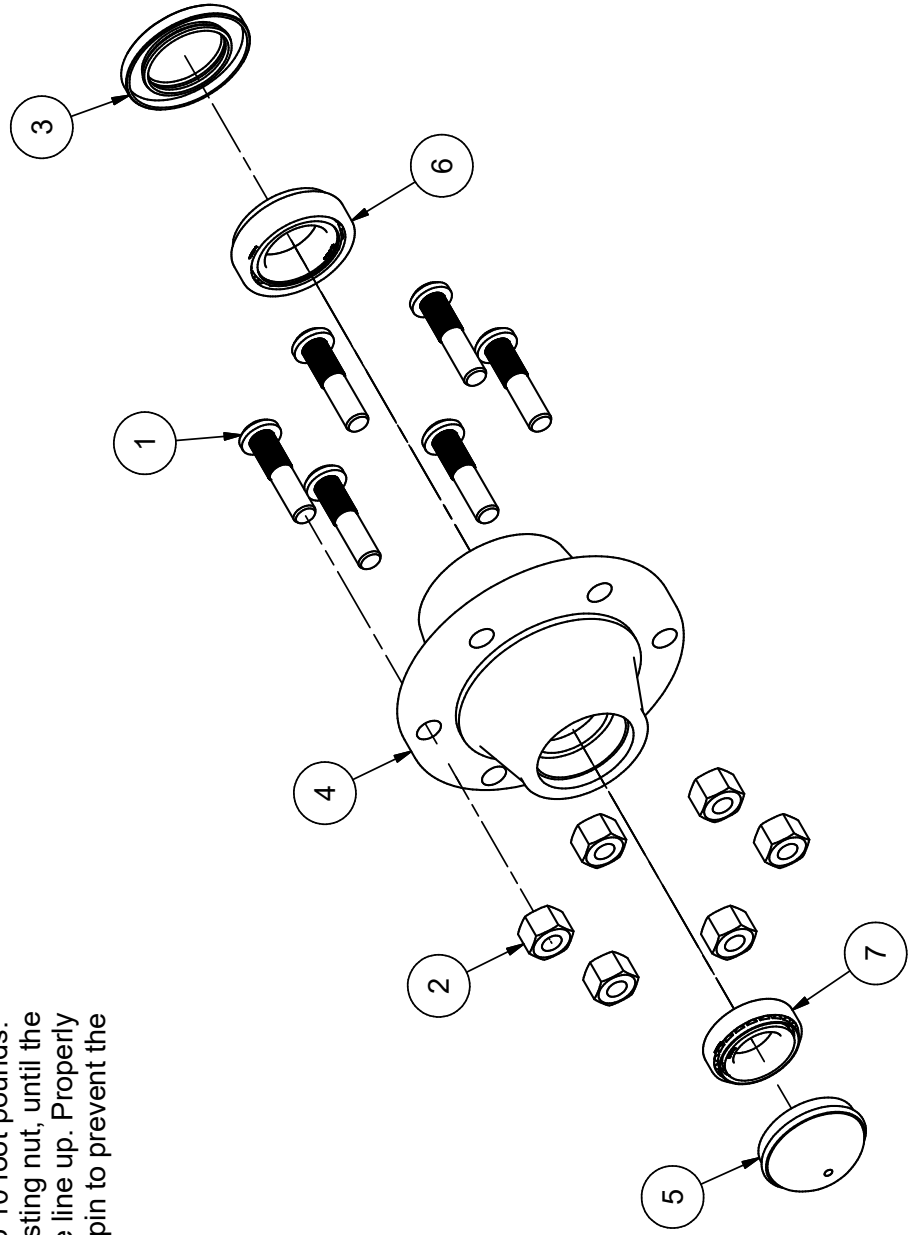

Parts List

ITEM	QTY	PART #	DESCRIPTION
1	12	110425	BOLT, 3/8-16 X 1.25
2	12	110672	WASHER, 3/8" LOCK
3	12	110676	WASHER, 3/8" FLAT STANDARD
4	12	110826	NUT, 3/8-16 GR 5
5	1	405021	ASSEMBLY, SIDE, FRONT
6	1	410076	SIDE, RIGHT/BACK
7	2	410135	RETAINER, SIDEBOARD
8	1	410196	BACKBOARD ASSEMBLY

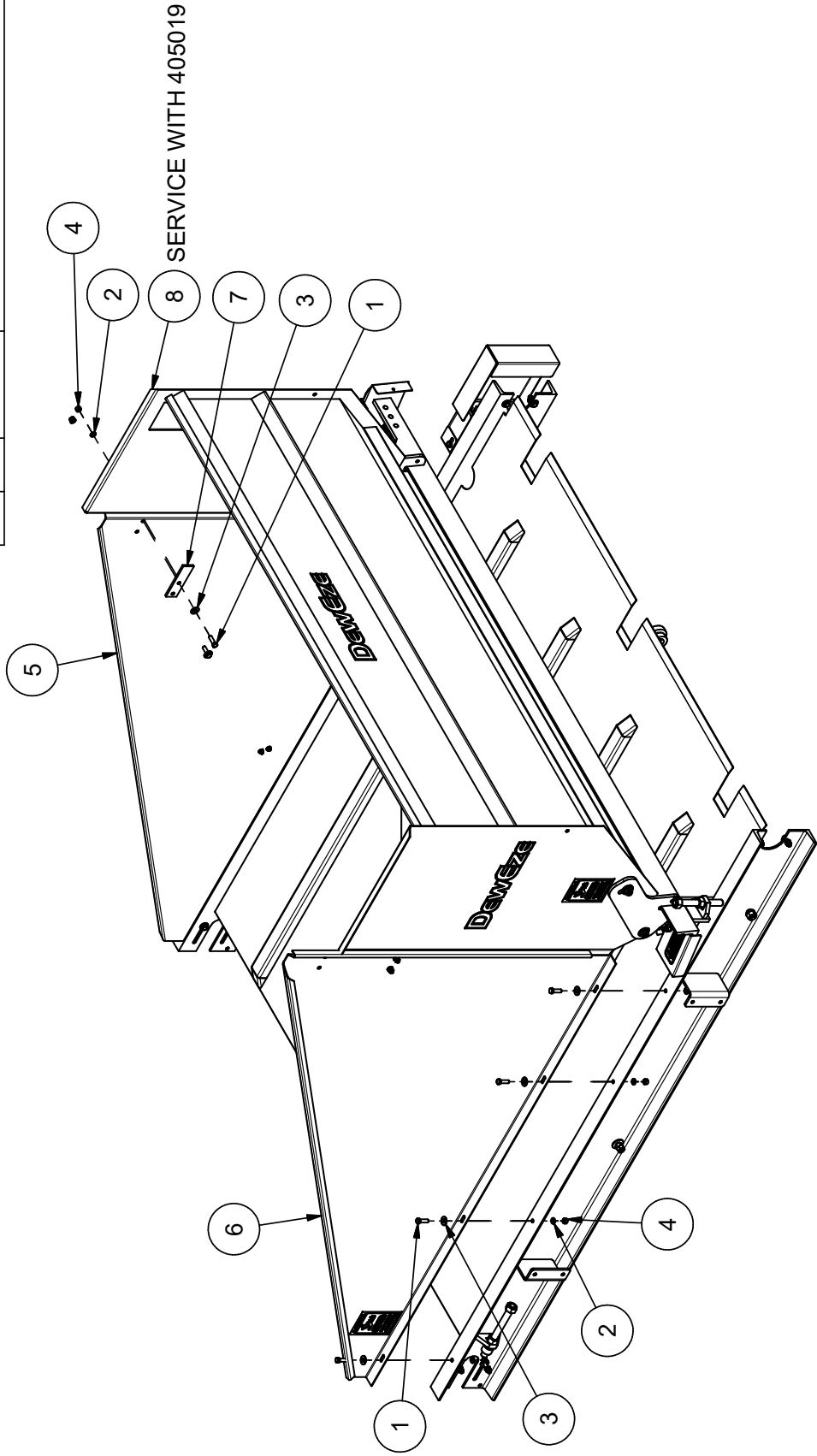

**Backboard and Sides**

5/4/2021

Other shields shown with their respective diagrams

ITEM	QTY	PART #	DESCRIPTION
1	2	210326	Clip, Hairpin
2	1	405006	Shield, Belt, Door Complete
3	1	405007	Shield, Belt, Moving, Complete
4	1	405022	Assembly, Shield
5	1	405026	Cover, Sickle Cover
6	1	102130	Pin, Linch, 0.25 X 1.5
7	4	110017	Bolt, 5/16 -18 X 1.75
8	2	110299	Bolt, 1/4 -20 X 0.625 Hex Gr 5
9	2	110339	Screw, 10-24x1.25 Pan Head
10	1	112105	Latch, Rubber T-Handle

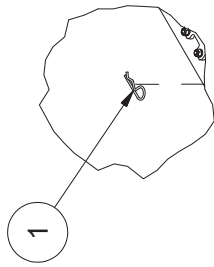

**DETAIL A**

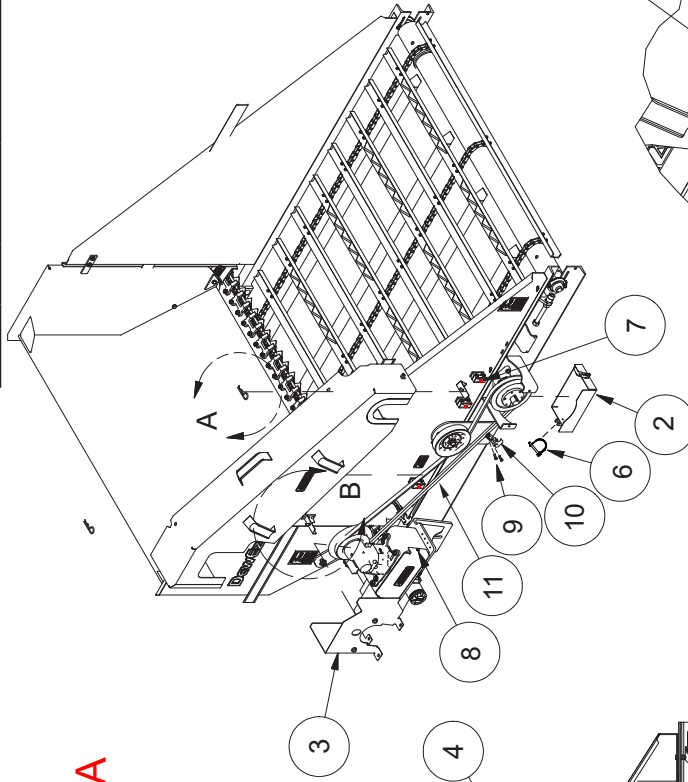

210326 clip  
installed here

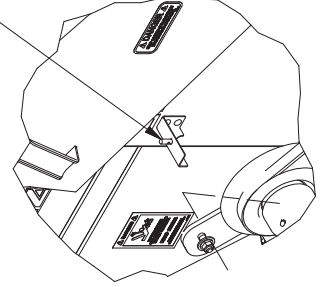

**DETAIL B**

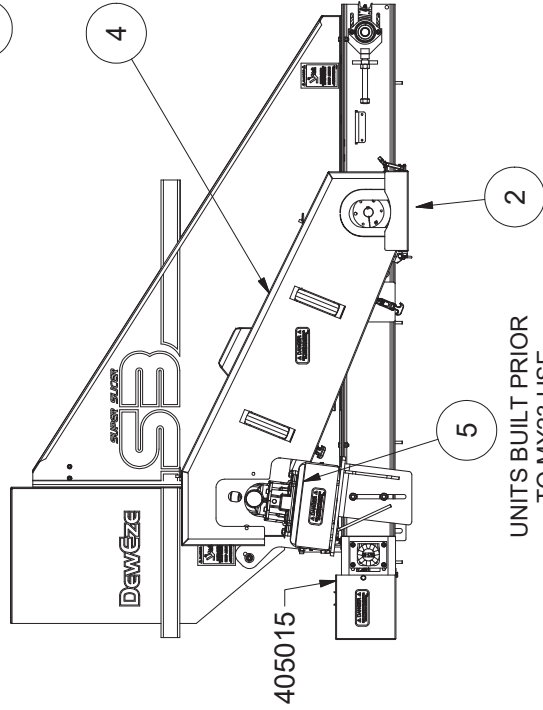

UNITS BUILT PRIOR  
TO MY23 USE  
405014

**Safety Shields**

Parts List

ITEM	QTY	PART #	DESCRIPTION
1	2	110442	BOLT, 1/2-13 X 1.25
2	4	110610	NUT, 1/2-13
3	1	415007	Table, complete
4	1	415010	Trailer Complete

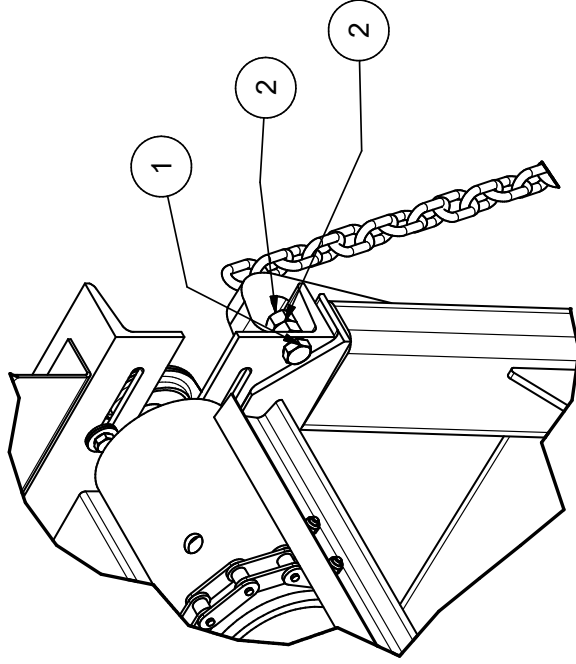
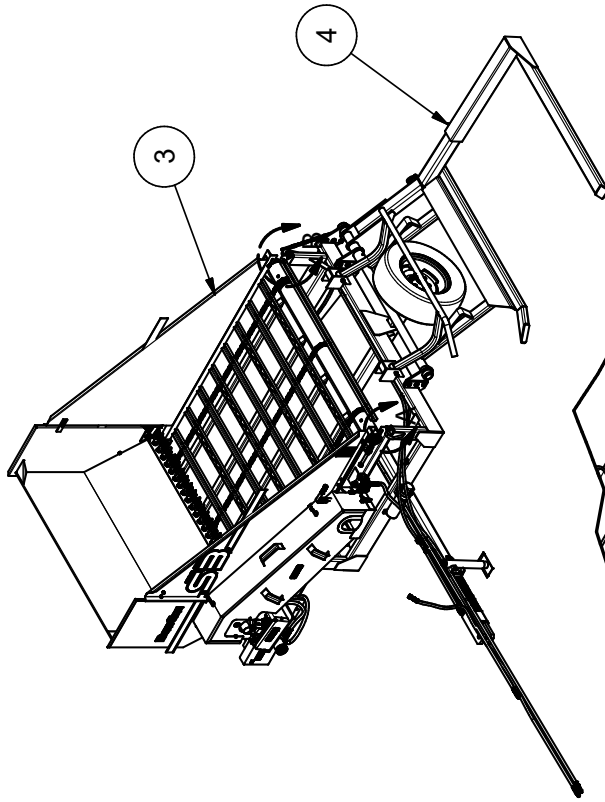

**DETAIL B**  
**SCALE 1 / 5**

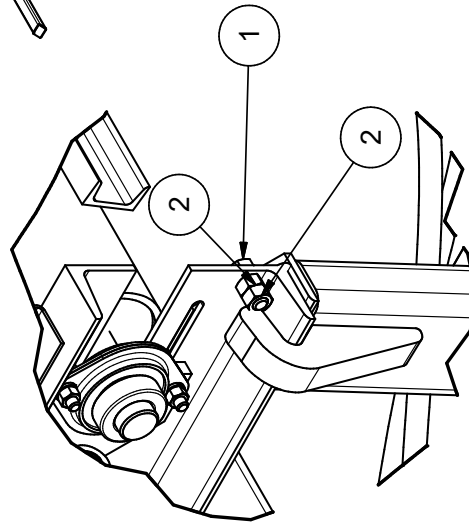

**DETAIL A**  
**SCALE 1 / 5**

**Table safety stops**



NET WRAP BOX ASSEMBLY: 405002

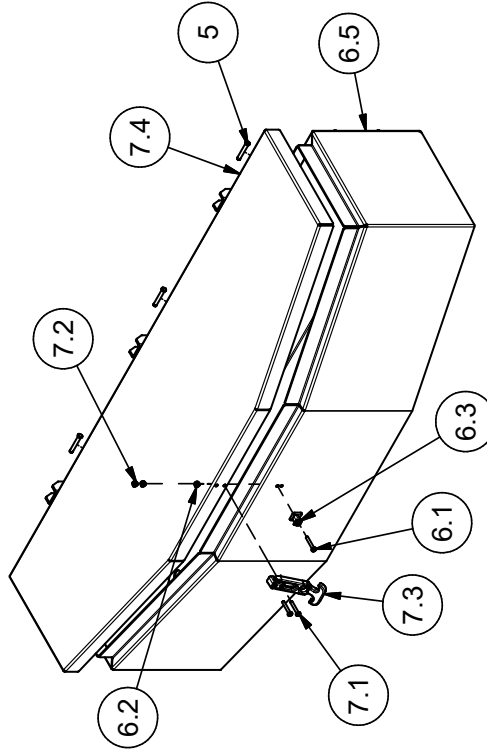
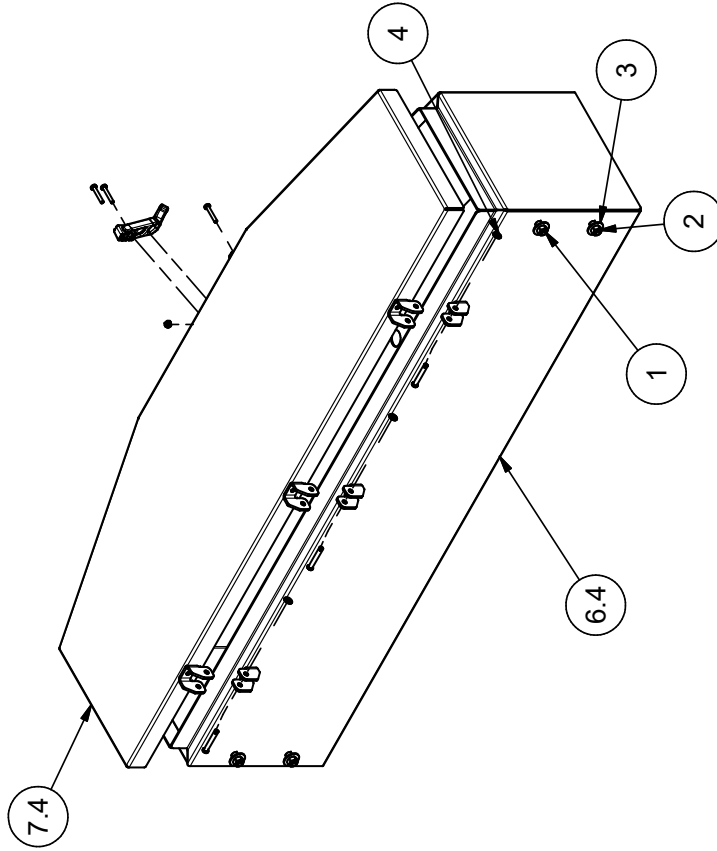
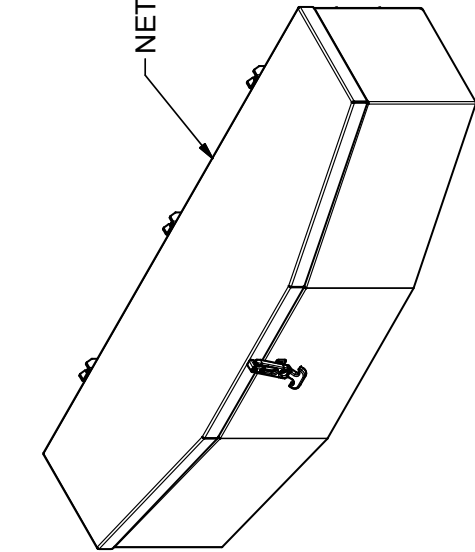

Parts List

ITEM	QTY	PART #	DESCRIPTION
1	4	110420	BOLT, 3/8-16 X 1.0
2	4	110621	NUT, 3/8-16, UNITORQUE LOCK
3	8	110676	WASHER, 3/8" FLAT STANDARD
4	3	112011	PUSH NUT, WASHER CAP STYLE
5	3	112095	CLEVIS PIN, STD ZP 1/4 X 1 5/8
6	1	415008	weldment, net wrap box, bottom
6.1	1	110339	SCREW, 10-24X1.25 PAN HEAD PHS
6.2	1	110631	NUT, 10-24 LOCK NYLON INSERT
6.3	1	112106	Keeper, Draw Latch
6.4	1	411545	bottom, net wrap box, S3
6.5	1	411546	front, net wrap box, S3
7	1	415009	weldment, net wrap box lid
7.1	2	110339	SCREW, 10-24X1.25 PAN HEAD PHS
7.2	2	110631	NUT, 10-24 LOCK NYLON INSERT
7.3	1	112105	LATCH, RUBBER T-HANDLE DRAW
7.4	1	411547	lid, net wrap box, S3

OPTIONAL NET WRAP BOX

1/29/2021



Other safety decals shown with their respective diagrams

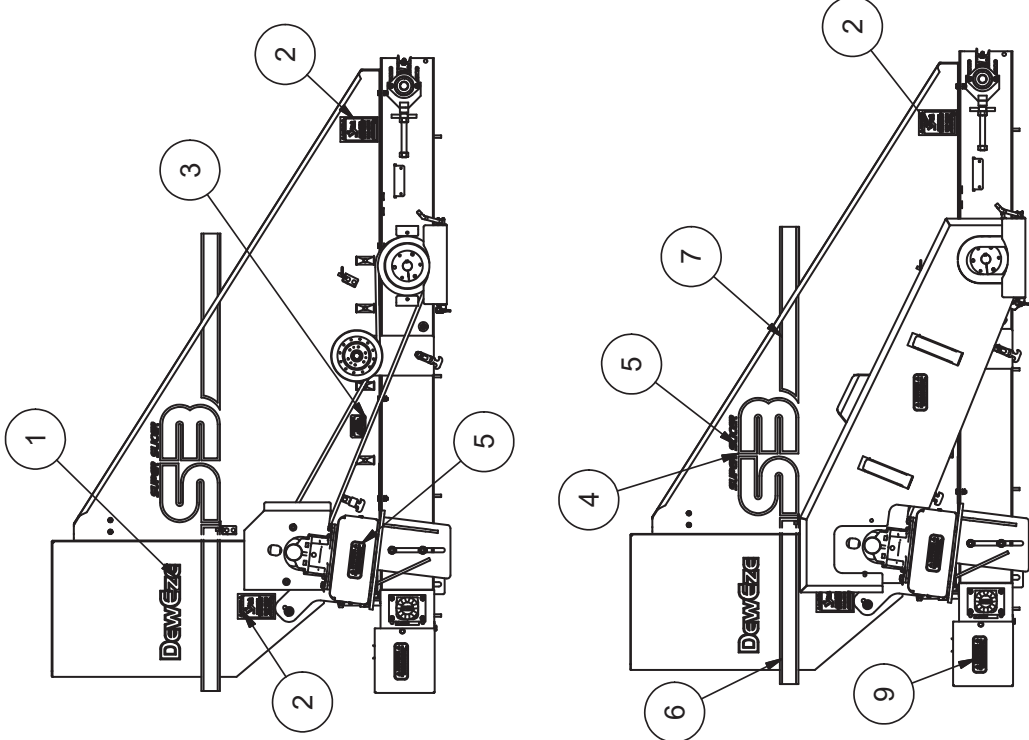

**Decals and Safety Decals**

Parts List

ITEM	QTY	PART #	DESCRIPTION
1	3	102138	DECAL, DEWEZE, SILVER ON BLACK
2	4	400012	Decal, Danger Moving Sickle
3	2	400014	DECAL, SHIELD REMOVED
4	3	400093	S3 decal
5	3	400094	Super Slicer (small) decal
6	2	400095	S3 straight stripe
7	2	400096	S3 scalloped stripe decal
8	1	405013	assembly, sickle end cover
9	4	500038	Decal, Danger Keep Covers In Place

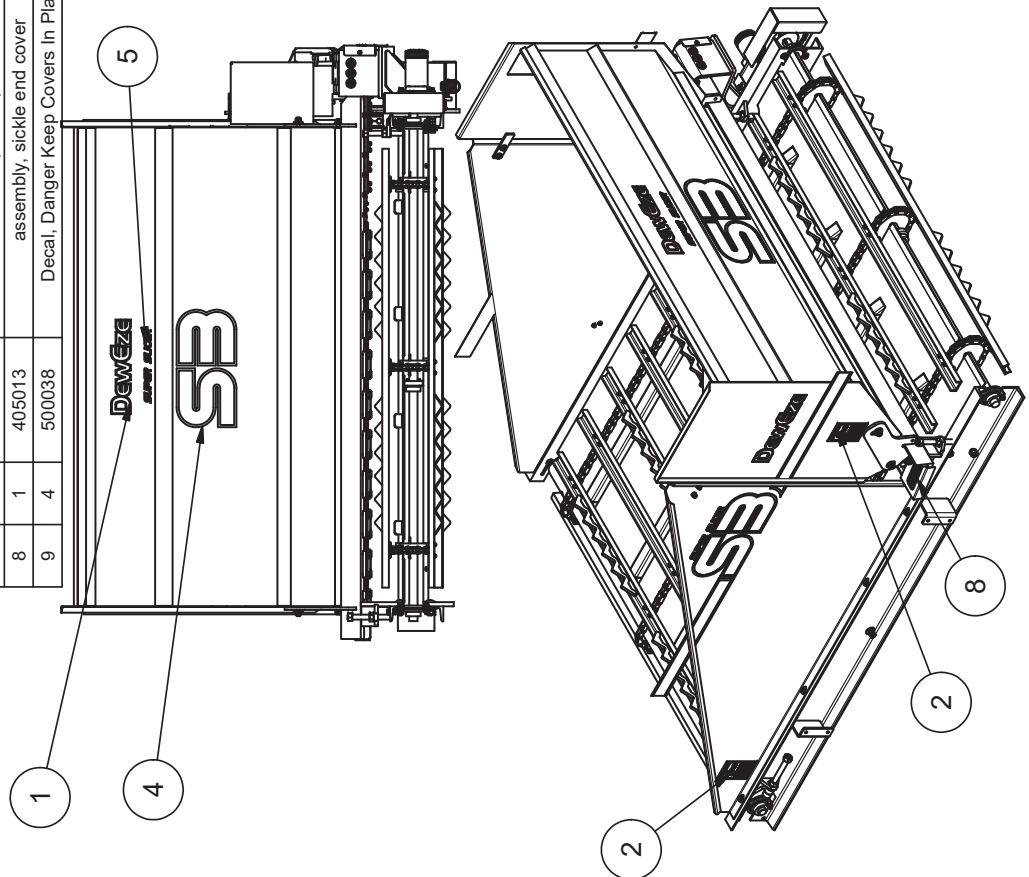

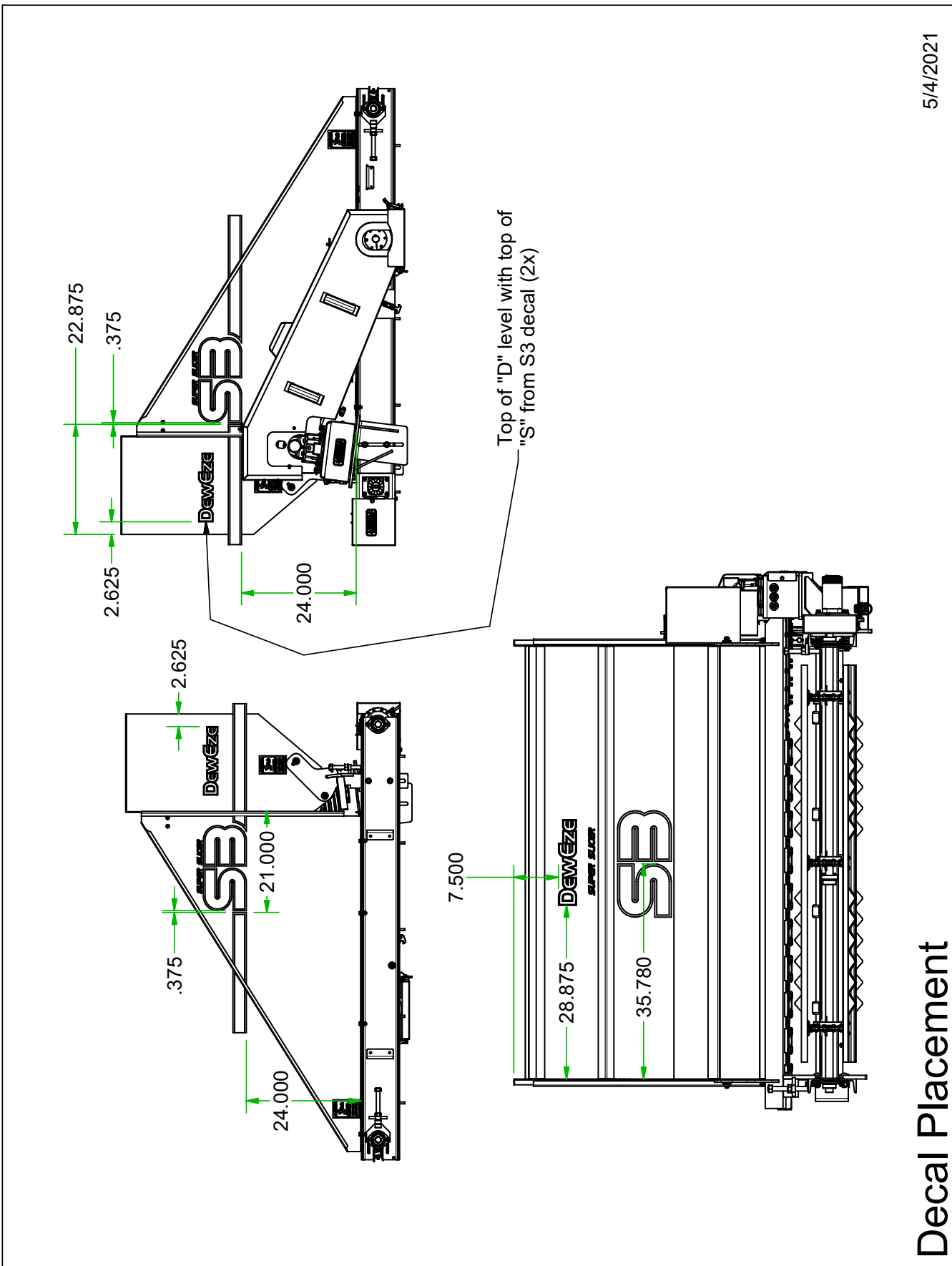

Decal Placement

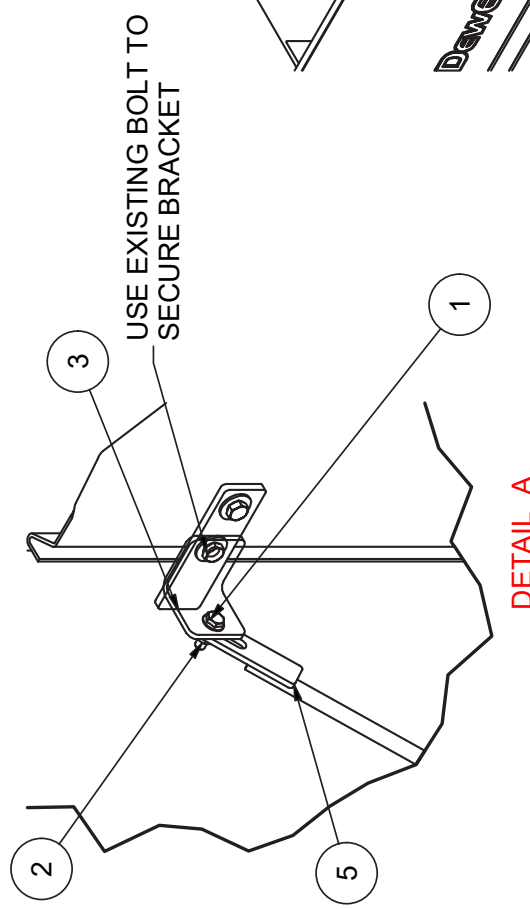

DETAIL A

USE EXISTING HARDWARE ON SICKLE GUARD TO SECURE BRACKET. SLIGHT DEFORMATION OF BRACKET WILL BE NEEDED WHEN TIGHTENING FASTENERS

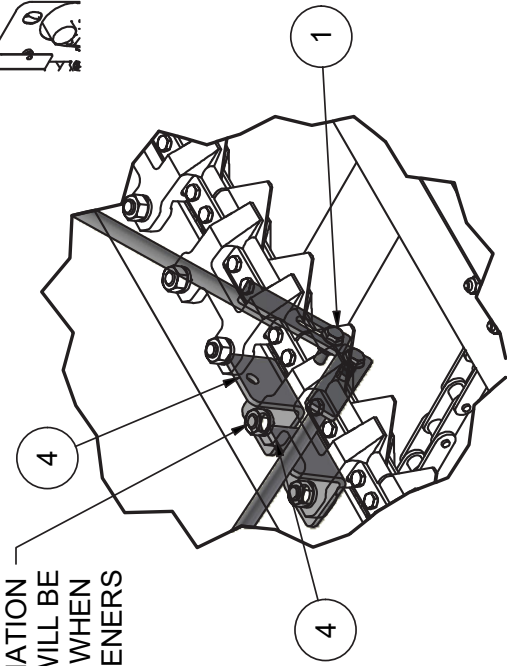

DETAIL B

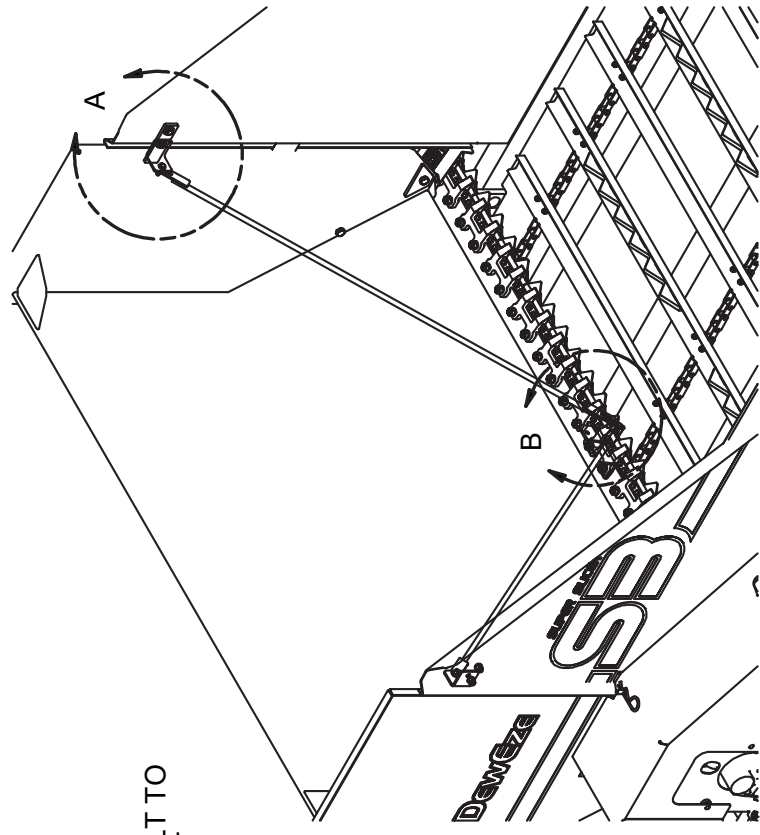

Parts List

ITEM	QTY	PART #	DESCRIPTION
1	4	110459	BOLT, 5/16-18 X 1, WIZ FLANGE
2	4	110606	NUT, 5/16-18 WIZ FLANGE
3	2	411577	ANGLE, S3 SHIPPING
4	2	411578	ANGLE, S3 SHIPPING
5	2	415023	WELDMENT, S3 SHIPPING ROD



This diagram covers the basic drive assembly for both hydraulic and PTO slicers

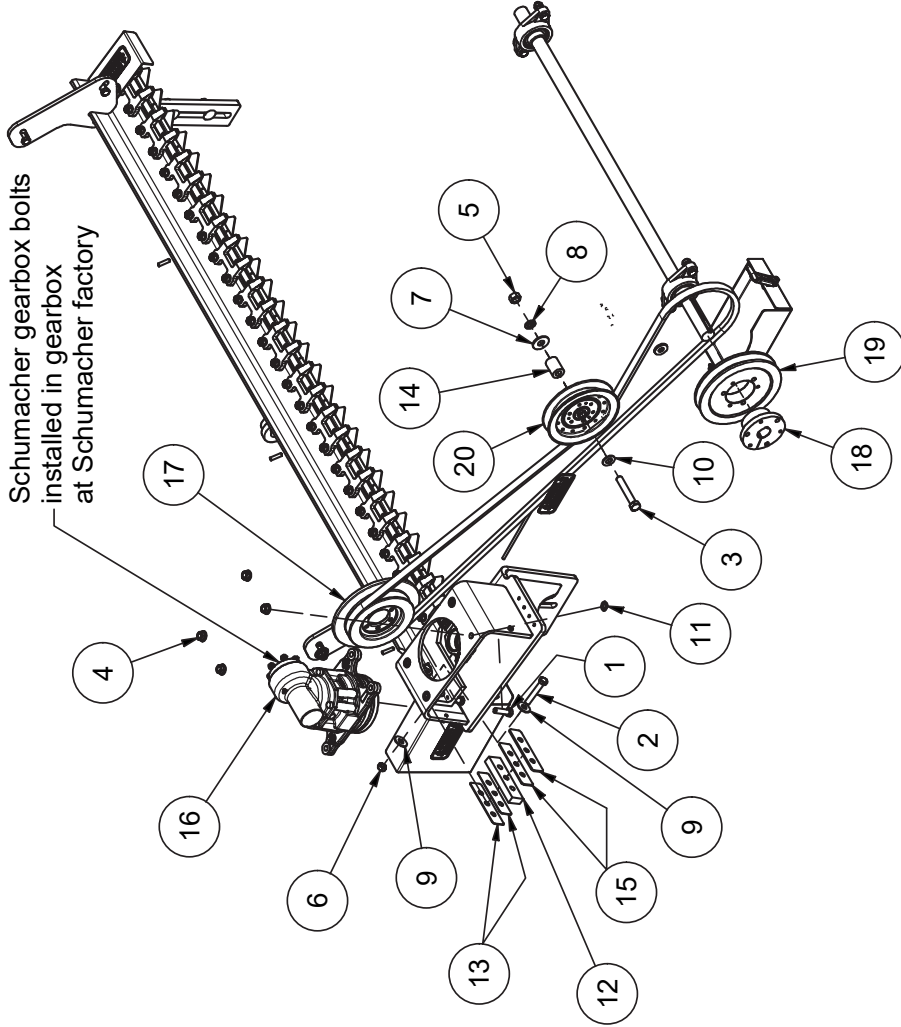

Parts List			
ITEM	QTY	PART #	DESCRIPTION
1	4	110419	BOLT, 1/2-13 X 1.75
2	3	110428	BOLT, 1/2-13 X 3.0
3	1	110510	BOLT, 5/8-11 X 3.75
4	8	110588	NUT, 1/2-13 WIZ FLANGE
5	3	110597	NUT, 5/8-11
6	3	110615	NUT, 1/2-13, UNITORQUE LOCK
7	1	110650	WASHER, 5/8" FLAT STANDARD
8	3	110655	WASHER, 5/8" LOCK
9	10	110658	WASHER, 1/2" FLAT STANDARD
10	1	110663	WASHER, 5/8" FLAT SAE
11	4	111172	WASHER, 1/2 INT. TOOTH LOCK
12	1	411535	Spacer, Pro Drive mount, S3
13	2	411536	Shim, Pro drive mount, S3
14	1	411543	spacer, tensioner pulley
15	2	411582	Shim 12 Ga., Pro drive mount, S3
16	1	440072	Schumacher Pro Drive
17	1	440073	pulley 180mm diameter
18	1	440079	QD SF 1 3/8" drive bushing
19	1	440080	1 C 85 SF
20	1	442006	pulley, 6 inch, Don Dye

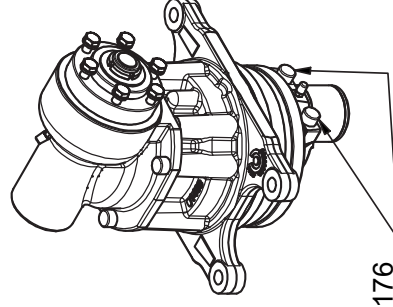

Service with Part Number 110176  
SHCS M10x35 Grade 12.9

# Sickle Drive Assembly

6/6/2024

Parts 2 and 3 can be found on the right side of the Schumacher gear box mount assembly

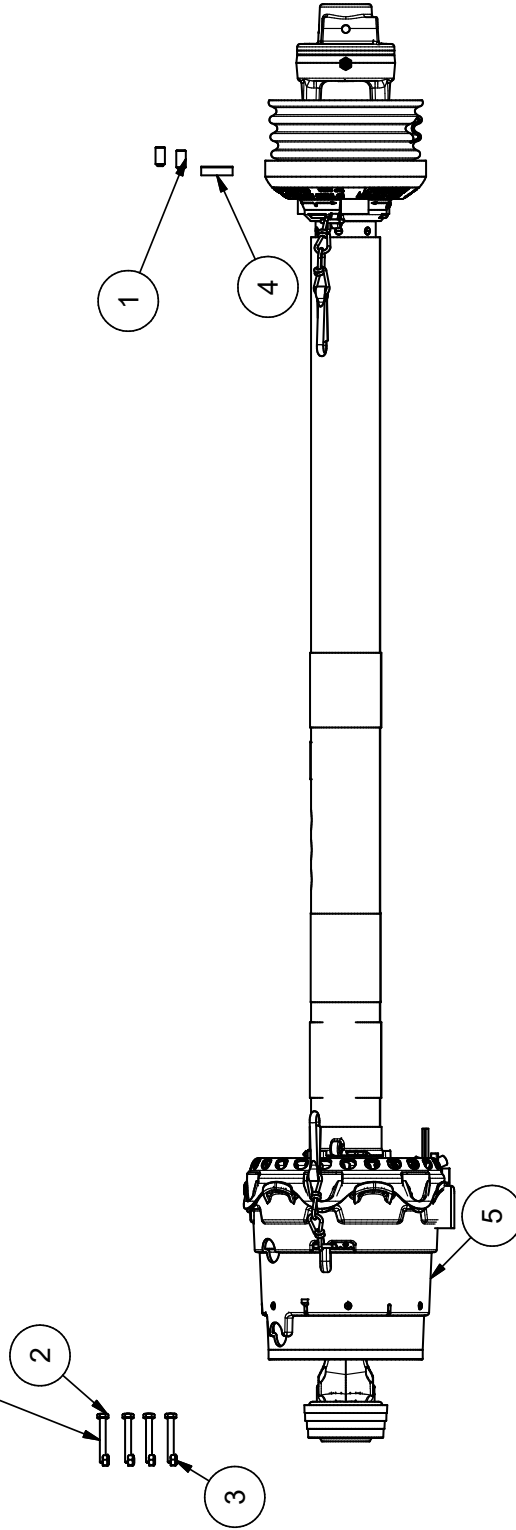

Weight: 11.57 lbmass

12/20/19

Parts List		
ITEM	QTY	DESCRIPTION
1	2	SetScrew, 3/8-16 X 0.75
2	4	BOLT, M6x1 x 45, Gr 8.8
3	4	Nut, M6 x 1, Top Lock
4	1	KEY 5/16" X 5/16" X 1 1/4"
5	1	PTO shaft, CV

PTO kit



## Sickle parts list

Parts List				Parts List			
ITEM	QTY	PART #	DESCRIPTION	ITEM	QTY	PART #	DESCRIPTION
1	20	110054	Bolt, 7/16-14 X 2.5 in Carriage	11	1	415005	Weldment, Sickle mount, S3
2	6	110535	BOLT, 7/16-14 X 1.5	12	1	440077	complete, sickle assy
3	26	110641	NUT, 7/16-14	12.1	1	440076	sickle, assy, S3
4	26	110671	WASHER, 7/16" LOCK	12.1.1	1	410192	Sickle Bar
5	1	400014	DECAL, SHIELD REMOVED	12.1.2	27	410193	Sickle Section, 3"
6	23	400031	Stub Guard, Super Slicer II	12.1.3	54	110630	NUT, 1/4-20 LOCK (NYLON INSERT)
7	1	405013	assembly, sickle end cover	12.1.4	43	110561	BOLT, 1/4-20 X .75
7.1	1	411542	shield, sickle end plate	12.1.5	11	110430	BOLT, 1/4-20 X 1-1/4
7.2	1	500038	Decal, Danger Keep Covers In Place	12.2	1	442004	Schumacher sickle connector
8	9	410710	PLATE, STUB GUARD ADJ.	12.3	1	442005	Schumacher nylon bushing
9	10	410711	SHIM, STUB GUARD	13	20	510161	SetScrew, 3/8-16 X 0.5
10	1	411539	Plate, notched stub guard, adj				

# PTO HOLDER

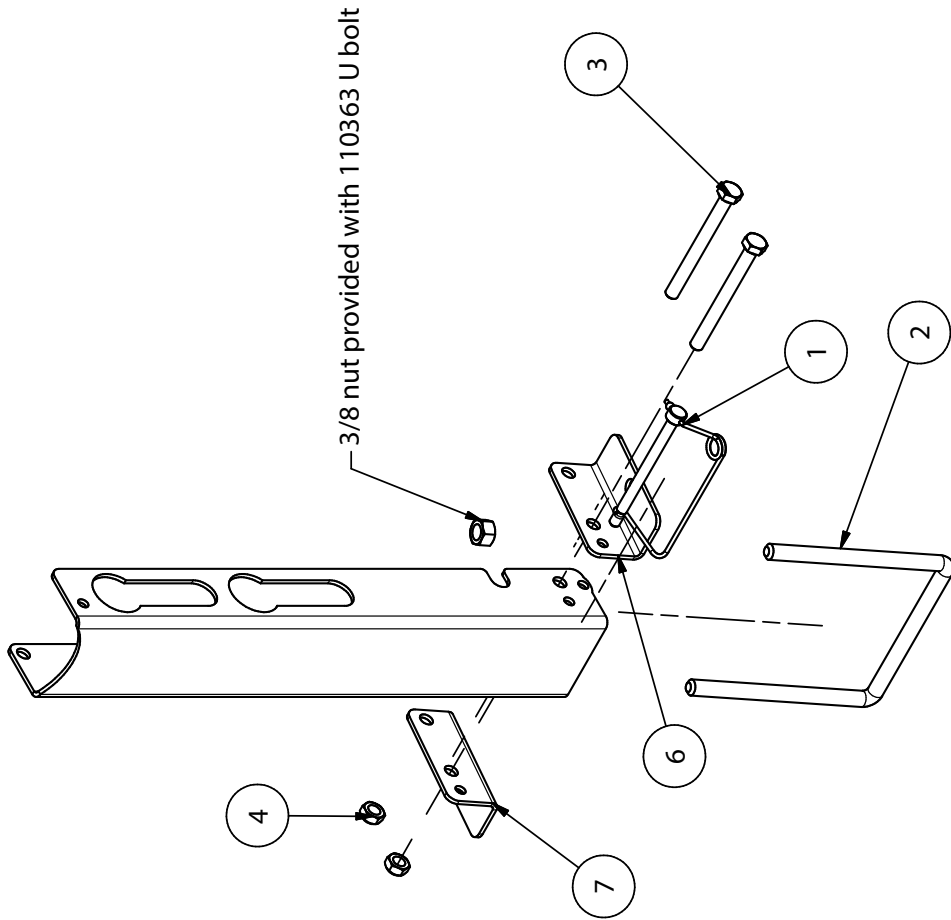

This side toward tongue of machine

5

### Parts List

ITEM	QTY	PART #	DESCRIPTION
1	1	102129	Pin, 1/4inch, .25 X 3.0
2	1	110363	BOLT, U, SQUARE 3/8 X 4 X 4 3/4
3	2	110536	BOLT, 5/16-18 X 3.25
4	2	110600	NUT, 5/16-18, UNITORQUE LOCK
5	1	411557	PTO shaft holder
6	1	411558	Base, PTO holder, right
7	1	411559	Base, PTO holder, left



Parts List

ITEM	QTY	PART #	DESCRIPTION
1	2	110410	BOLT, 1/4-20 X 2.5
2	2	110609	NUT, 1/4-20
3	2	110667	WASHER, 1/4" LOCK
4	1	120224	ADAPTER, 10MJ-10MB90
5	1	120251	ADAPTER, 10MJ-10MB
6	1	120258	ADAPTER, 10MJ-10MJ-10MB
7	2	120320	ADAPTER, 10MJ-10MB45
8	1	420147	valve, flow control,-10 SAE (FCR51-10-2600)
9	1	420152	HOSE .5 X 68.8 8-10F JX/8-10F JX45
10	1	420153	HOSE .5 X 160.4 8-10F JX/8-8MB
11	1	420154	HOSE .5 X 155.6 8-10F JX/8-8MB
12	1	420155	HOSE .5 X 73.8-10F JX/8-10F JX90L

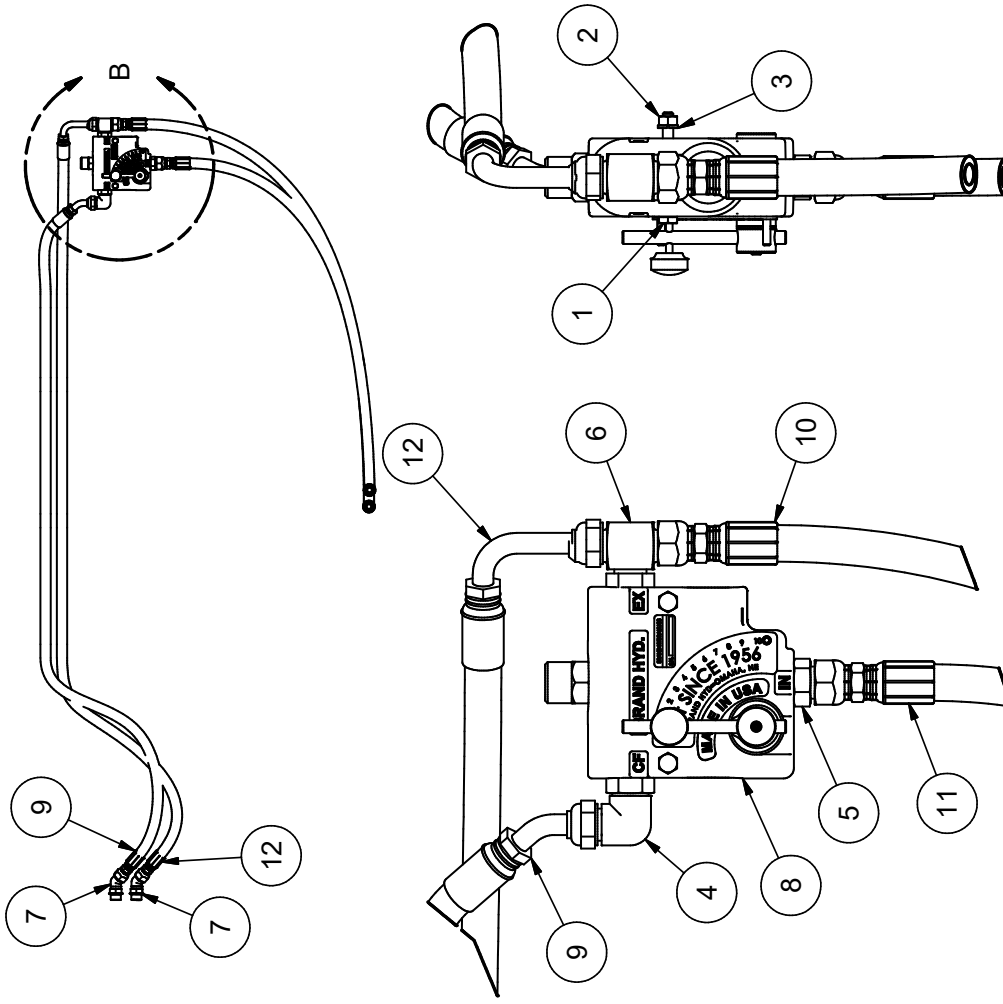

DETAIL B  
SCALE .25

# Hose Assembly - PTO Version

4/22/2021

Parts List			
ITEM	QTY	PART #	DESCRIPTION
1	1	420152	HOSE .5 X 68.8 8-10FJX/8-10FJX45
2	1	420155	HOSE .5 X 73 8-10FJX/8-10FJX90L

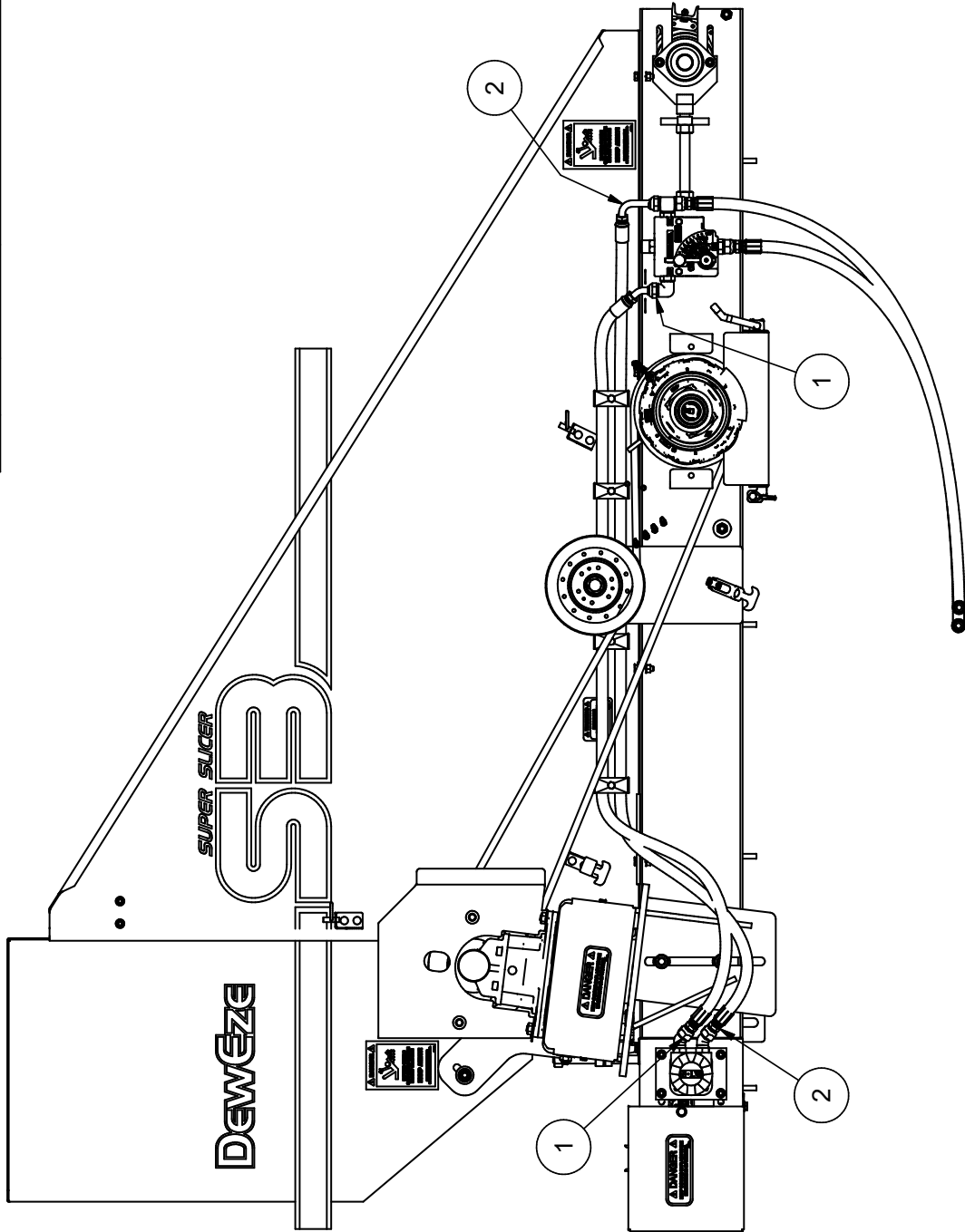

Hose Assembly - PTO Version

Parts List

ITEM	QTY	PART #	DESCRIPTION
1	2	110377	BOLT .5/16-18 X 1-1/2
2	2	110410	BOLT .1/4-20 X 2.5
3	6	110420	BOLT .3/8-16 X 1.0
4	2	110608	NUT .5/16-18
5	4	110609	NUT .1/4-20
6	4	110665	WASHER .5/16" FLAT STANDARD
7	3	110665	WASHER .1/4" LOCK
8	6	110672	WASHER .3/8" LOCK
9	1	110673	WASHER .1/4" FLAT STANDARD
10	2	110674	WASHER .5/16" LOCK
11	1	110727	CLAMP ADEL .75WX.75DX.406HOLE
12	2	110826	NUT .3/8-16 GR.5
13	2	111892	BOLT .1/3-20 X 2.75 HHCS gr 5
14	3	120224	ADAPTER .10ML-10MB90
15	3	120251	ADAPTER .10ML-10MB
16	2	120320	ADAPTER .10ML-10MB-10MJ
17	2	120661	ADAPTER .10ML-10MB-10MJ
18	1	120730	ADAPTER .10ML-10FJX45
19	1	410229	Coupler, Sprocket, flex. 1" Kss
20	1	410230	Chain, Motor Drive Coupler
21	1	410262	Coupler, Sprocket, flex. 1.3/8 K
22	1	410389	KEY .5/16" X .5/16" X 1.1/4"
23	1	410442	Connecting Link #60 Chain
24	1	411540	Mount plate, Hydraulic belt drive motor, S3
25	1	411549	bracket, hydraulic valve
26	1	420139	Motor, Schumacher Drive 101-1011-009
27	2	420147	valve, flow control,-10 SAE(FCR51-10-2600)
28	1	420154	HOSE .5 X 155.6.8-10FJX/8-8MB
29	1	420156	HOSE .5 X 13.8-10FJX/8-10FJX
30	1	420157	HOSE .5 X 20.8.8-10FJX/8-10FJX90L
31	1	420158	HOSE .5 X 23.2.8-10FJX/8-10FJX
32	1	420159	HOSE .5 X 66.7.8-10FJX/8-10FJX
33	1	420160	HOSE .5 X 73.6.8-10FJX/8-10FJX
34	1	420162	HOSE .5 X 171.7.8-10FJX/8-10FJX90L

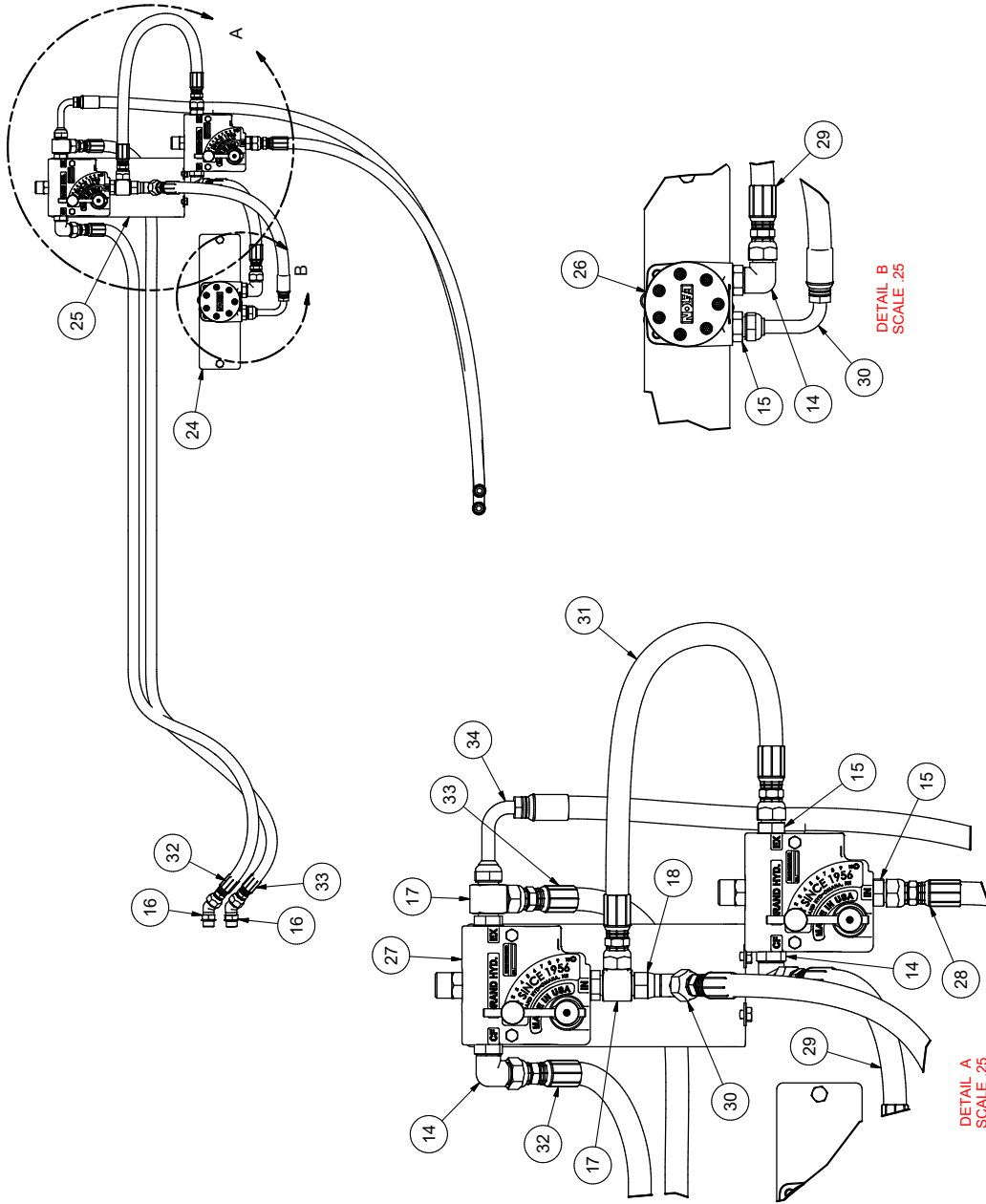

Hose Assembly - Hydraulic Version

Parts List

ITEM	QTY	PART #	DESCRIPTION
1	2	110377	BOLT, 5/16-18 X 1-1/2
2	2	110410	BOLT, 1/4-20 X 2.5
3	6	110420	BOLT, 3/8-16 X 1.0
4	2	110608	NUT, 5/16-18
5	4	110609	NUT, 1/4-20
6	4	110665	WASHER, 5/16" FLAT STANDARD
7	3	110667	WASHER, 1/4" LOCK
8	6	110672	WASHER, 3/8" LOCK
9	1	110673	WASHER, 1/4" FLAT STANDARD
10	2	110674	WASHER, 5/16" LOCK
11	1	110727	CLAMP, ADEL, 75WX, 75IDX, 406HOLE
12	2	110826	NUT, 3/8-16 GR 5
13	2	111192	BOLT, 1/3-20 X 2.75 HHCS 97 5
14	3	120224	ADAPTER, 10MJ-10MB90
15	3	120251	ADAPTER, 10MJ-10MB
16	2	120320	ADAPTER, 10MJ-10MB45
17	2	120661	ADAPTER, 10MJ-10MB-10WJ
18	1	120730	ADAPTER, 10MJ-10FJX45
19	1	410228	Coupler, Sprocket, flex, 1" Kss
20	1	410230	Chain, Motor Drive Coupler
21	1	410262	Coupler, Sprocket, flex, 1.3/8 K
22	1	410389	KEY 5/16" X 5/16" X 1 1/4"
23	1	410442	Connecting Link, #60 Chain
24	1	411540	Mount plate, Hydraulic belt drive motor, S3
25	1	411549	bracket, hydraulic valve
26	1	420139	Motor, Schumacher Drive 101-1011-009
27	2	420147	valve, flow control, -10 SAE(F CR51-10-2600)
28	1	420154	HOSE .5 X 13.8-10FJX8-10FJX
29	1	420156	HOSE .5 X 13.8-10FJX8-10FJX
30	1	420157	HOSE .5 X 20.8-10FJX8-10FJX90L
31	1	420158	HOSE .5 X 23.2-10FJX8-10FJX
32	1	420159	HOSE .5 X 66.7-10FJX8-10FJX
33	1	420160	HOSE .5 X 73.5-10FJX8-10FJX
34	1	420162	HOSE .5 X 171.7-10FJX8-10FJX90L

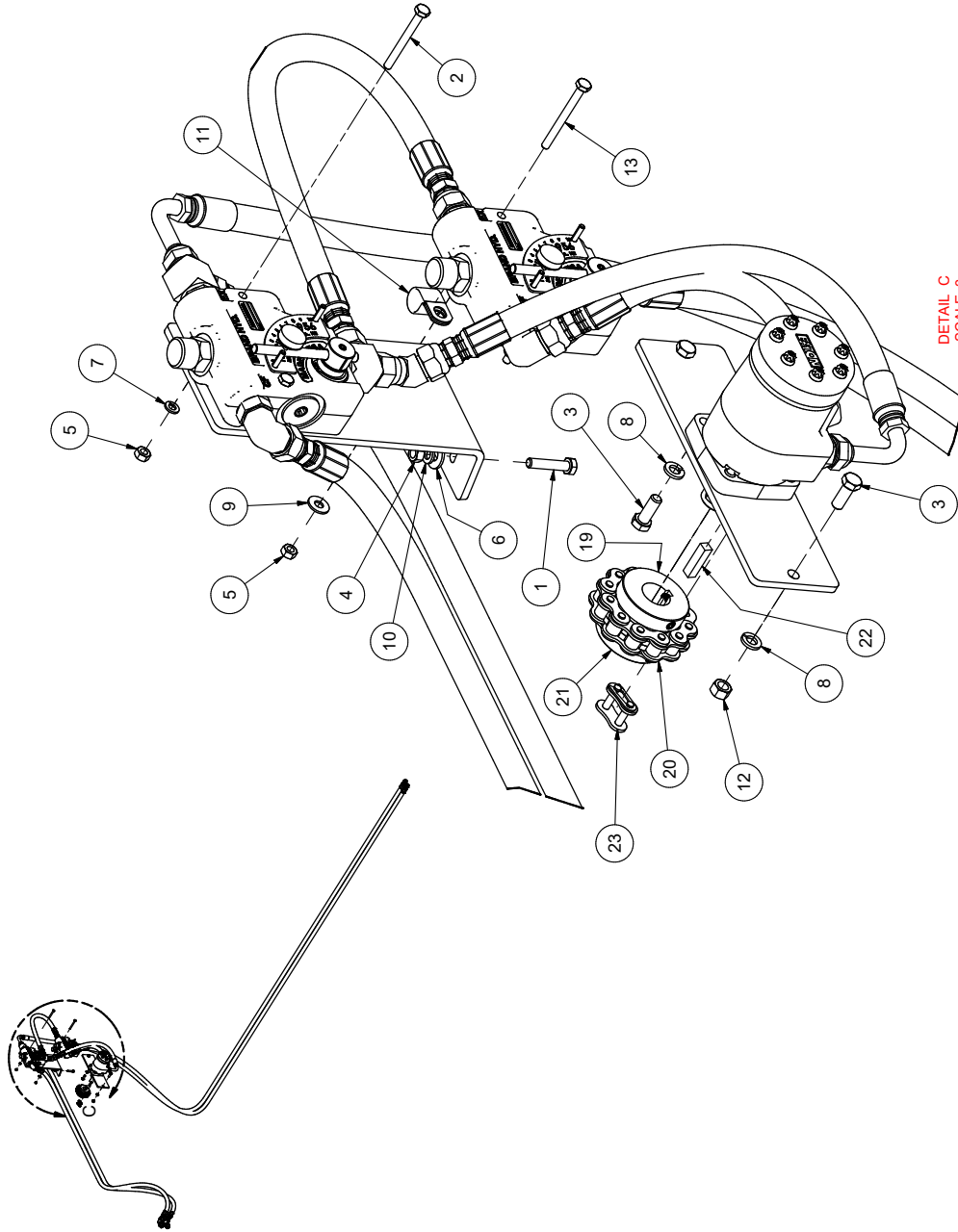

DETAIL C  
SCALE .3

Hose Assembly - Hydraulic Version

Parts List		
ITEM	QTY	PART # DESCRIPTION
1	1	420154 HOSE .5 X 155.6 8-10FJX8-8MB
2	1	420156 HOSE .5 X 13.8-10FJX8-10FJX
3	1	420157 HOSE .5 X 20.8 8-10FJX8-10FJX90L
4	1	420158 HOSE .5 X 23.2 8-10FJX8-10FJX
5	1	420159 HOSE .5 X 66.7 8-10FJX8-10FJX
6	1	420160 HOSE .5 X 73.5 8-10FJX8-10FJX
7	1	420162 HOSE .5 X 171.7 8-10FJX8-10FJX90L

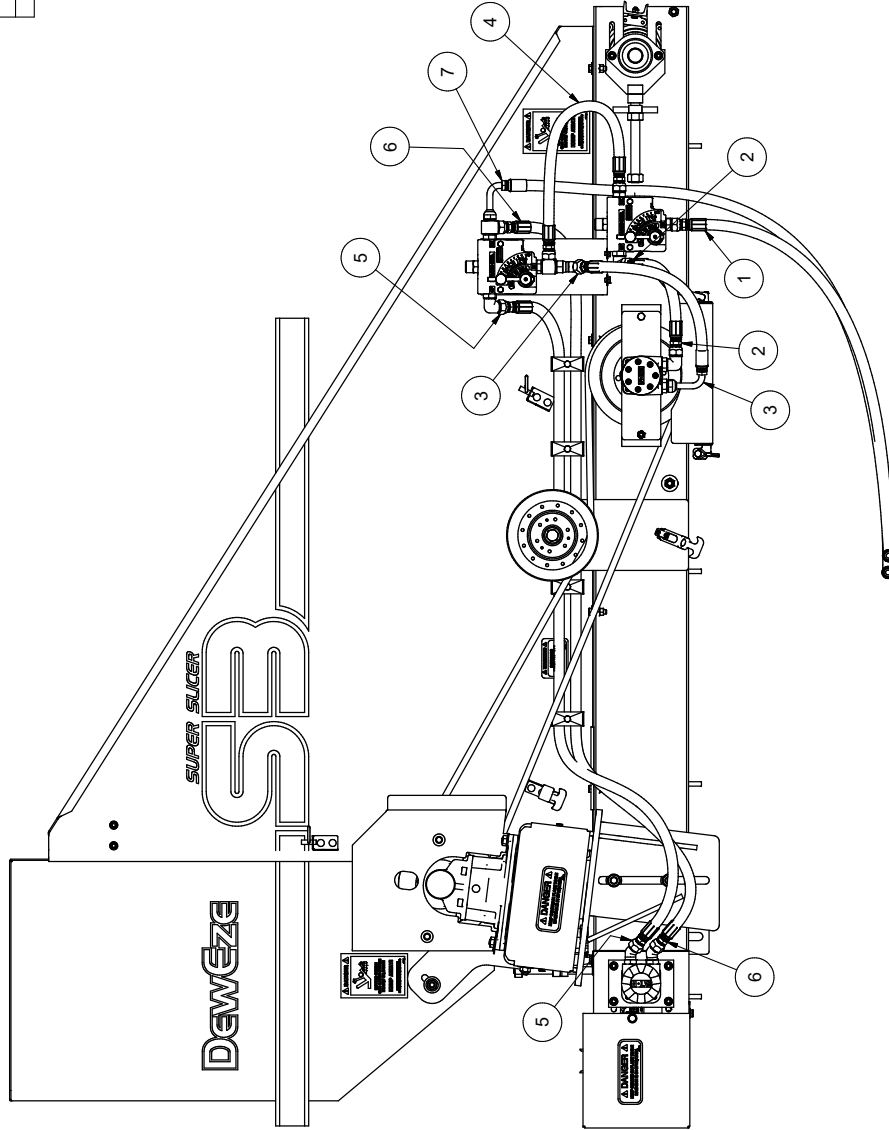

Hose Assembly - Hydraulic Version

4/29/2021

## NOTES

Harper Industries, Inc.  
151 E. Highway 160  
Harper, KS 67058

Telephone: 620-896-7381  
Toll-Free: 800-835-1042  
Fax: 620-896-7129

Website: [www.harperindustries.com](http://www.harperindustries.com)

E-mail: [info@harperindustries.com](mailto:info@harperindustries.com)